



INNOVATORS IN MOTION TECHNOLOGY
CATALOGUE 2000 N.A.

 **Darcor** 

Darcor's ergonomic logo symbolizes...

work-efficient, worker-friendly casters.

Darcor is the standard for ergonomically designed casters.



Darcor Limited

TORONTO - BUFFALO - LOS ANGELES

Tel: 1-800-387-7206 or 1-416-255-8563

Fax: 1-800-465-6544 or 1-416-251-6117

www.darcor.com

www.casterdesign.com

casters@darcor.com

7 Staffordshire Place, Toronto, Ontario M8W 1T1

HISTORY

Darcor: Past, Present, Future

Darcor Casters originated in Toronto, Canada in 1931 as an importer and manufacturer of high quality wheels and casters. The company was purchased by Robert Hilborn in 1975. This was followed by a period of feverish product development which continues to this day. During those evolutionary years, Darcor grew into a multifaceted manufacturing operation with a powerful commitment to quality and innovation using advanced in-house facilities.

Throughout the company's history, Darcor's vision has remained steadfastly in the future anticipating the proliferating demand for specialty casters in today's rapidly evolving manufacturing environment. And responding with uniquely

designed products that blend ergonomic principles and advanced materials to improve bottom-line results and workplace conditions.

That is how Darcor has developed – and continues to increase – its enviable reputation for keeping business in motion across North America and around the globe.



A

A

B

C

D

16

6 4 A

INSTALLATION OPTIONS

		PAGE
*	TOP PLATE *(SPECIFY PLATE NUMBER)	16
O*	GRIP RING STEM *(SPECIFY SIZE CODE)	14/15
L*	THREADED STEM *(SPECIFY SIZE CODE)	14/15
PB*	PIPE STEM *(SPECIFY SIZE CODE)	14/15
PC*	PIPE CAP *(SPECIFY SIZE CODE)	14/15
S*	SQUARE STEM *(SPECIFY SIZE CODE)	14/15
JA	STEM FOR METAL SOCKETS	14/15
WSA	WOOD LEG STEM	14/15
C*	CLINCHED SWIVEL *(SPECIFY SIZE)	14/15

COMPLETE CASTER

A - B C D - E F

WHEEL ONLY

W* - B C - E F

W* Designates Wheel Only

B

C

LOAD RANGE LBS./CASTER	SERIES DESIGNATION	WHEEL DIAMETER	PAGE	STANDARD TOP PLATE
75	E2 ETERNITY II	2"	18	NA
125	53 CARPETMASTER	3"	19	NA
75-125	20 SERIES EXAMPLES = 22-22.5-23-24-25	2"-2.5"-3"-4"-5"	20	#12
200-400	30 SERIES EXAMPLES = 32-32.5	2"-2.5"-3"-4"	22	#16
175-400	60 SERIES EXAMPLES = 62.5-63-63.5-64-65	2.5"-3"-3.5"-4"-5"	24	#16
300-600	70 SERIES EXAMPLES = 73-74-75-76	3"-4"-5"-6"	26	#31
400-1000	400 SERIES EXAMPLES = 403-404-405-406-408	3"-4"-5"-6"-8"	28	#31
1350-2200	700 SERIES EXAMPLES = 705-706-708-710	5"-6"-8"-10"	31	#6
1300-1800	800 SERIES EXAMPLES = 805-806-808-810	5"-6"-8"-10"	30	#8
1200-3500	900 SERIES EXAMPLES = 906-908-910-912	6"-8"-10"-12"	32	#6
2000-5000	5000 SERIES EXAMPLES = 5006-5008-5010-5012	6"-8"-10"-12"	33	#5000
1400-10000	5200 SERIES EXAMPLES = 5206-5208-5210-5212	6"-8"-10"-12"	34	#5200
300-2700	300/3000 PNEU EXAMPLES = 308-310-3016-3018 EXAMPLES = 3216-3218-3318	8"-10"-16"-18"	35	#6 #5200

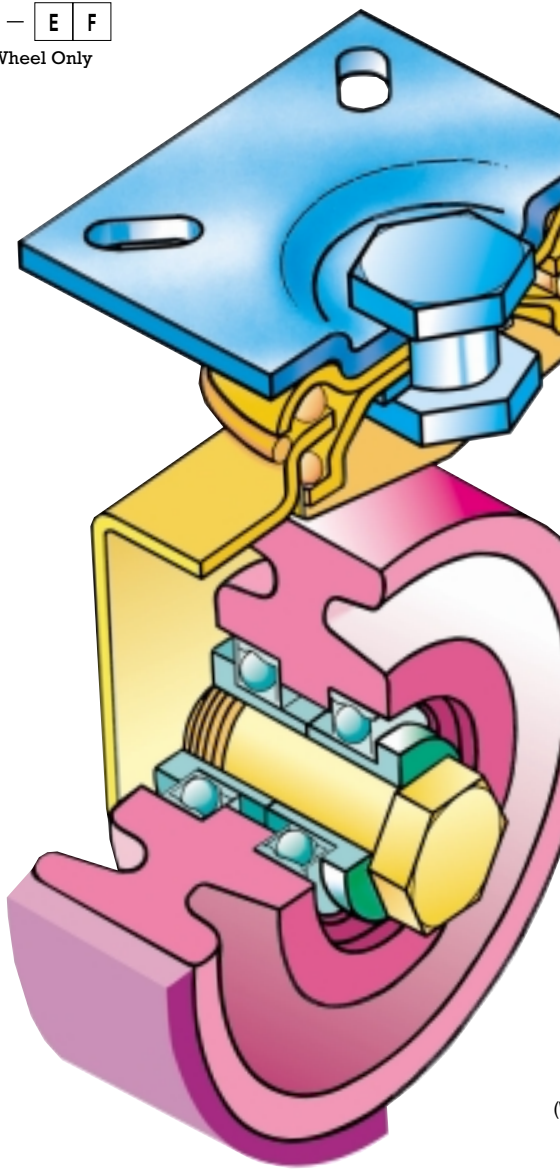

TORONTO - BUFFALO - LOS ANGELES
Tel: 1-800-387-7206 or 1-416-255-8563
Fax: 1-800-465-6544 or 1-416-251-6117

DARCOR CASTER MODEL NUMBER GUIDE

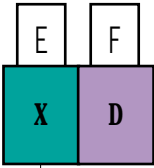

D OPTIONS	
SEE PAGE 9 FOR MORE INFORMATION	
R	RIGID CASTER
B	BRAKE
F2	TWO POSITION SWIVEL LOCK
F4	FOUR POSITION SWIVEL LOCK
A	COMBINATION BRAKE AND 4 POSITION SWIVEL LOCK
S	SEALED SWIVEL WITH GREASE FITTINGS IN SWIVEL AND AXLE.
G	GREASE FITTING IN AXLE ONLY

E BEARING TYPE	
SEE PAGE 10 FOR MORE INFORMATION	
X	BALL
T	ROLLER
P	PRECISION SEALED BALL BEARING
Y	TAPERED ROLLER
M	DELRIN
OMIT	PLAIN SLEEVE

F TREAD MATERIAL	
SEE PAGE 7 FOR MORE INFORMATION	
D	NEOPRENE
SR	SUPER ROLL NEOPRENE
SE	SOLID ELASTOMER
U	POLYURETHANE
CI	SEMI-STEEL
H	HARD RUBBER
K	SEMI-RESILIENT RUBBER
CV	V-GROOVE-SEMI-STEEL
N	INDUSTRIAL RUBBER
PN	PNEUMATIC

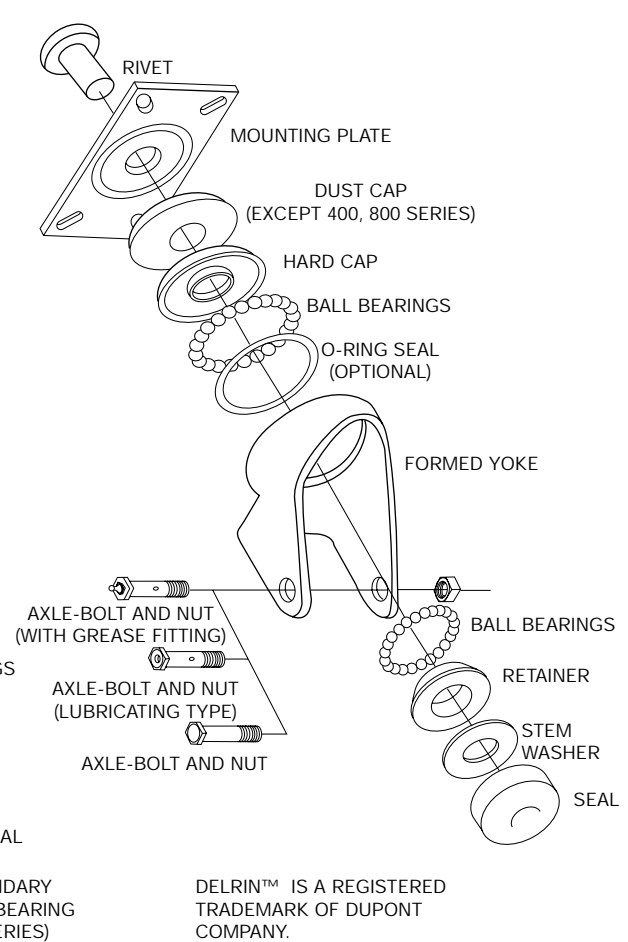
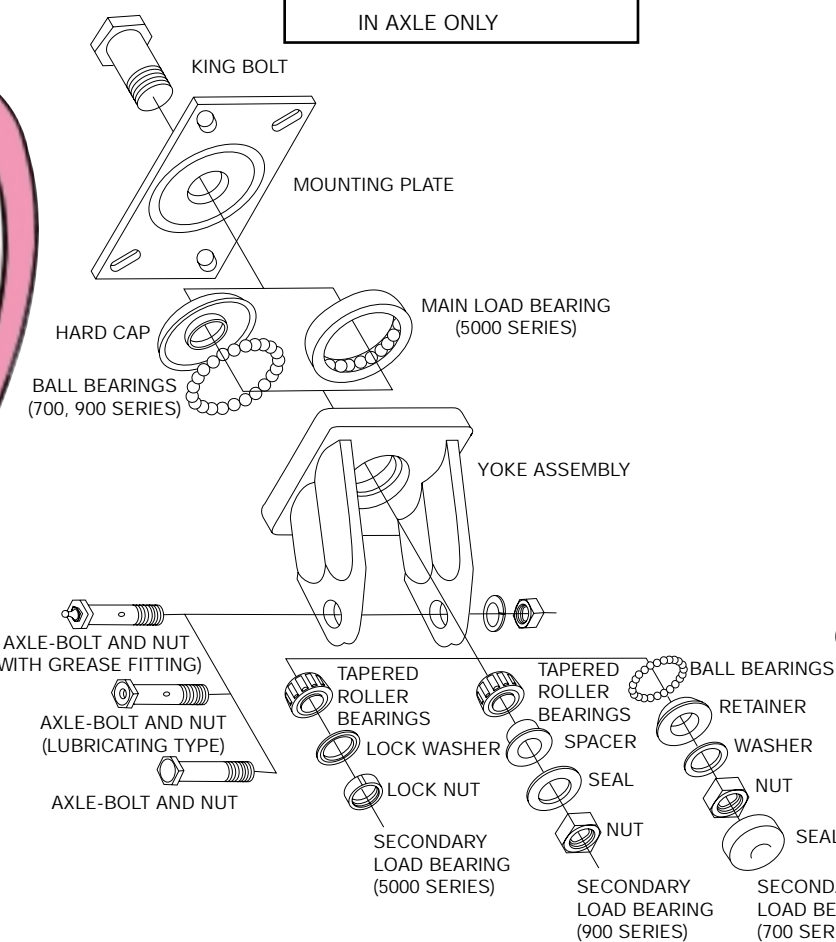

DELRIN™ IS A REGISTERED TRADEMARK OF DUPONT COMPANY.

SPECIALTY CASTERS: *SEE PAGES 36-47.



Darcor's ergonomic logo symbolizes work - efficient, worker - friendly casters. Darcor is the standard for ergonomically designed casters.

GUARANTEE

We are proud of the casters we manufacture. Visit our manufacturing facilities and you will see the evidence of that pride in the care and attention to detail focused on each caster – from the design stage, through production, to shipping and after-sale service.

To some, quality control is a marketing strategy; to us, it is a way of business life. That is why our comprehensive line of casters has won a worldwide reputation for reliability, longevity and, perhaps most importantly, usefulness.

We manufacture a wide variety of casters, ranging from the Carpet Master office chair caster to our heaviest casters rated to a load capacity of 60,000 lbs. In between, you'll find ... well, casters of almost any size or style you can imagine.

The reason for all these choices is not to fill catalogue pages. It is to ensure we can provide you with the bolt-hole pattern, the caster size and height, the wheel material that is perfectly useful for your needs.

And, if we can't deliver what you need from stock, we'll be happy to design and manufacture a specialty caster that delivers maximum usefulness. And we'll do it quickly, efficiently and economically. (We're flexible that way – your way!)

What sets us apart from other caster manufacturers is people. Sure, we have state-of-the-art design and manufacturing systems and processes. Certainly, our quality controls and strict adherence to technical specifications are second to none. But it is the caliber of our dedicated and versatile employees which has allowed Darcor to establish a standard of excellence that is far above the rest.

Personal Customer Service

Our customer service personnel are experienced professionals. They know casters and can match our products to your needs. If you have any questions about specifications, pricing, delivery information or any wheel or caster listed in this catalogue, just give our "problem solvers" a call. They'll be happy to get you moving the best possible way: on a Darcor caster.

Our Guarantee

Every Darcor product is warranted against defects in material and workmanship for a period of one year from the date of original purchase. Any product defective because of material or workmanship returned with the prior written approval of Darcor's Quality Control Department, within the warranty period, will be repaired or replaced, free of charge, non-inclusive of freight and installation, if delivered, transportation and shipping charged prepaid, to Darcor factory located at 7 Staffordshire Place, Toronto, Ontario M8W 1T1 or Darcor Caster C/O ABF Transport, 50 Flyder Ave., Tonawanda N.Y. 14150. This guarantee does not include any product that has been abused, misused, improperly installed, mishandled, not used for the purpose intended, used under severe or adverse conditions.

SERVICE



The laws of some states in the U.S. may limit or prohibit exclusion or limitation of written or implied warranties; therefore, any portion of this Limited Warranty held void shall be deemed severed from the balance.

Designs

Dimensions and designs are subject to change without notice.

Shipping Terms

- Shipments F.O.B. Buffalo, New York
- Shipments F.O.B. Los Angeles, California
- Shipments F.O.B. Toronto, Ontario

Return Goods Policy

Return goods shipment requires prior authorization and a return goods number from Darcor.

A charge will be applied to cover the handling and restocking, providing goods are resaleable and do not require refurbishing.

No cancellations after the start of production.

No specially manufactured casters may be returned.



TORONTO - BUFFALO - LOS ANGELES
Tel: 1-800-387-7206 or 1-416-255-8563
Fax: 1-800-465-6544 or 1-416-251-6117

7 Staffordshire Place, Toronto, Ontario M8W 1T1

HOW TO SELECT THE PERFECT CASTER & WHEEL

Darcor offers you a wide variety of caster types and wheel options – and for good reason. Choosing the correct caster for the job and the work environment dramatically increases the life and performance of the caster – as well as enhancing its ergonomic benefits.

Here's how to select the perfect Darcor caster for your needs:

LOAD CAPACITY

This is your most important criterion for caster choice. In general, each caster should have the capacity to support one-third of the total load weight. That is because overloading, uneven floors and/or uneven load distribution may place a heavier burden on one or more casters.

To determine the required caster load capacity add the weight of the load and the weight of the cart, then divide by three.

MAXIMUM MOBILITY

The larger the wheel size (and swivel radius), the greater the mobility. The type of bearing selected will also further improve mobility and reduce rolling resistance.

Darcor's Neoprene, Super Roll Neoprene, Solid Elastomer, and Polyurethane offer maximum mobility in any application they are required for.

Your choice should be dictated by conditions in the work environment.

TREAD MATERIALS AND CASTER TYPES

Floor Conditions – Check for rough or uneven surfaces – joints, grates, potholes – oil, grease or chemicals, and note any carpeted areas.

Darcor Neoprene (D & SR) wheels are recommended for all types of floor conditions up to a load capacity of 270 kg per caster. For moderate to heavy loads, our Solid Elastomer (SE) wheels are an excellent choice. And for the heaviest loads, choose Polyurethane or Steel wheels.

Environmental Conditions - Check for dust, humidity and temperature extremes. Are the floors littered with debris or metal scraps?

Darcor Cart Washable™ Casters are ideal in areas with sprays or wash down requirements. The sealed swivels and rust-inhibiting finish add extra life. Sealed swivels are also a good idea where there is grinding action, lint or dust. They are also quiet – a consideration in hospitals.

APPLICATION CONSIDERATIONS

Check the speed of your operation. Are you using tow-line vehicles or Automatic Guided Vehicles (AGVs)? Most casters are rated for "walking speed". Higher speed applications decrease their load capacity and can increase heat build-up.

Darcor Solid Elastomer (SE) wheels are a perfect "high speed" choice. In continuous use, they don't build up heat, are easy to maneuver with less effort and, because of their exceptionally low rolling resistance, actually extend the "in-use" time for battery powered vehicles.

CONTENTS

HISTORY OF DARCOR.....	2
DARCOR CASTER SYSTEM GUIDE.....	3 - 4
HOW TO SELECT A CASTER.....	5
CONTENTS.....	5
THE INCREDIBLE ERGONOMIC WHEELS AND CASTERS FROM DARCOR	6 - 7
WHEEL MATERIALS AND SELECTION GUIDE.....	8 - 9
ACCESSORIES.....	9
BEARINGS AND AXLES.....	10
APPLICATIONS	11 - 12
DARCOR STATEMENT.....	13
CORPORATE PROFILE.....	14-17
OPTIONAL TOP PLATE	18
GLOSSARY OF TERMS.....	19
OFFICE CHAIR CASTERS.....	20 - 21
20 SERIES.....	22 - 23
30 SERIES	24
40 SERIES	25
60 SERIES.....	26 - 27
70 SERIES.....	28 - 29
400 SERIES.....	30 - 31
800 SERIES.....	32 - 33
H700 SERIES	34
900 SERIES	35
5000 SERIES.....	36
5200 SERIES.....	37
SPRING LOADED CASTERS.....	38 - 39
SPECIAL APPLICATION CASTERS	40
HOSPITAL CASTERS	41 - 43
NEOPRENE WHEELS.....	44 - 45
SOLID ELASTOMER	46
DARCOR URETHANE WHEELS.....	47
SEMI-STEEL WHEELS.....	48
SOLID ELASTOMER GUIDE.....	49-52
SERVICE AND GUARANTEE.....	53



Darcor's ergonomic logo symbolizes work - efficient, worker - friendly casters. Darcor is the standard for ergonomically designed casters.

The Incredible Ergonomic casters from Darcor

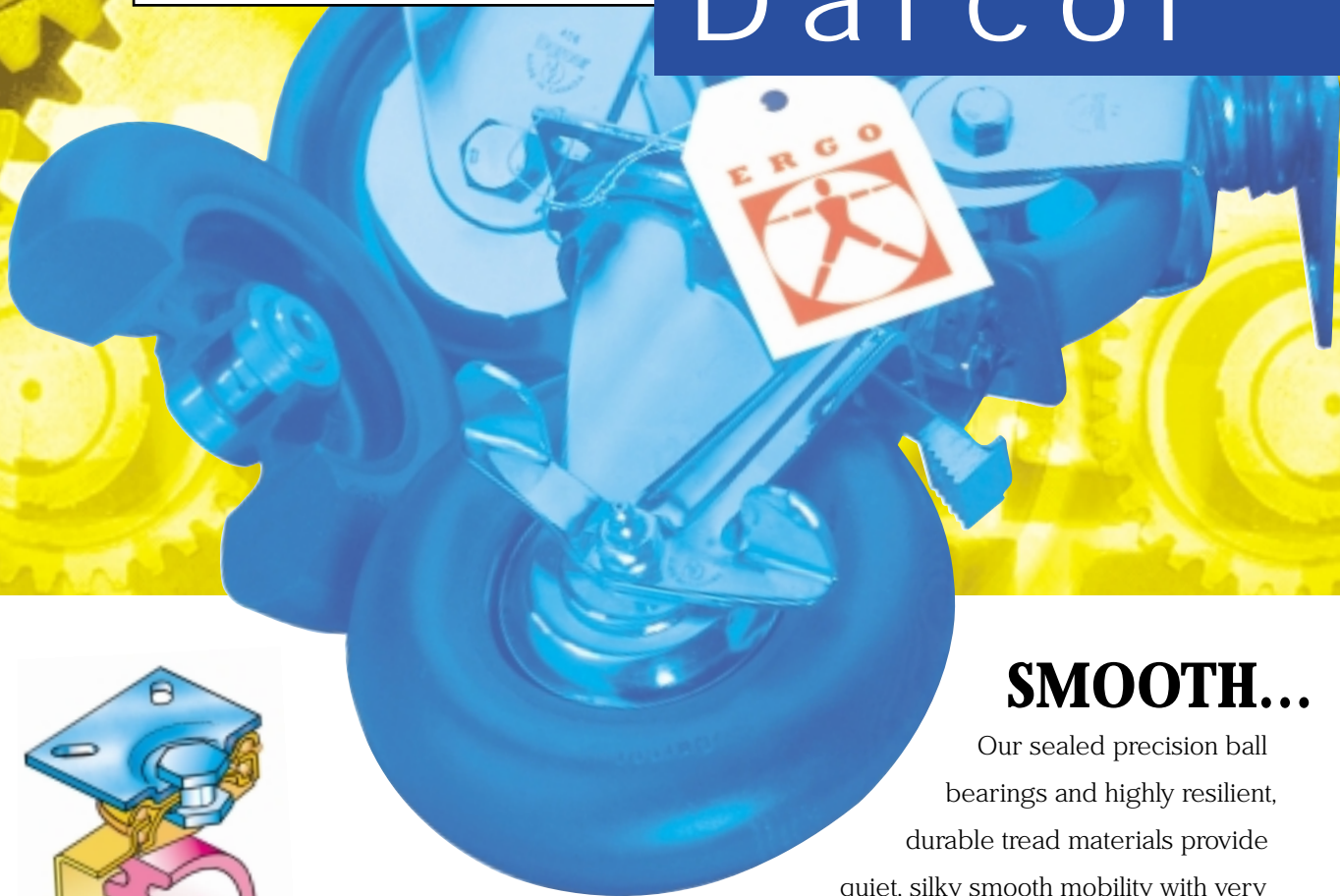

SMOOTH...

Our sealed precision ball bearings and highly resilient, durable tread materials provide quiet, silky smooth mobility with very long life. It takes so little force to move an 'SE' wheel that one person can easily manoeuvre a 1200 kg load. The silent and smooth rolling 'D' and 'SR' wheels have an extraordinary ability to **roll over obstacles** and floor litter (**glass, metal cuttings, plastic resin pellets**) without stopping or jarring the cart or embedding in the tread. Darcor Casters are the perfect problem solvers.

Wheel Performance Profile	PSE	PD	XD	XSR
* very easy to push	Y	Y	Y	Y
* minimal wear in extended use	Y	Y	Y	Y
* very quiet	Y	Y	Y	Y
* shock absorbing	Y	Y	Y	Y
* low heat build up	Y	Y	Y	Y
* resists abrasion	Y	Y	Y	Y
* resist harsh chemicals	Y	Y	Y	Y
* high speed operation	Y	Y	Y	Y
* non marking non staining	Y	Y	Y	Y
* oil resistance	Y	Y	Y	Y

TOUGH...

Tough conditions are a way of life for Darcor Datryl™ 'SE' and Neoprene 'D' and 'SR' Super Roll Wheels and Casters. These exceptional casters are designed to survive the harshest environments and operating conditions. They have proved their worth in thousands of miles of use, over years of service in applications worldwide. Darcor wheels stay in shape, protect floors and always swivel and roll freely. They can greatly **reduce back strain**.

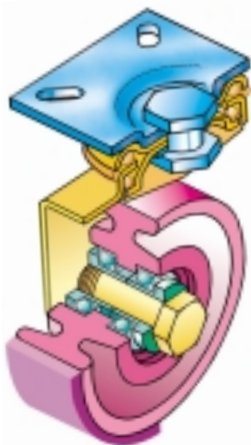

**DARCOR CASTERS
ARE ENGINEERED
AND MANUFACTURED
TO STRINGENT
STANDARDS FOR
STRENGTH,
RELIABILITY AND
EXTENDED LIFE.**

DARCOR ERGONOMIC CASTERS

Typical 31- 406 -PSE
 Model ! ! !
 Code ! ! Bearing Type & Wheel Material
 ! Caster Series & Wheel Diameter
 Type of Mounting Plate or Stem Size and Type
 Use "W-" for Wheels only e.g. (W-406-PSE)

Note: Mounting Plates shown are standard.
 Other plates, stems and CARTWASHABLE™ finish are available.

WHEEL DIAMETER mm	TREAD WIDTH mm	CARRYING CAPACITY kg	SWIVEL MODEL NUMBER	FIXED MODEL NUMBER	SWIVEL RADIUS mm	OVERALL HEIGHT mm
XD AND PD-SILENT-SHOCK RESISTANT-EASY ROLLING-ALL TERRAIN						
75	35	90	16-63-XD	16-63R-XD	70	111
100	35	100	16-64-XD	16-64R-XD	83	137
100	51	230	31-404-PD	31-404R-PD	93	143
125	35	110	16-65-XD	16-65R-XD	102	162
125	51	250	31-405-PD	31-405R-PD	108	170
150	41	160	31-76-XD	31-76R-XD	124	192
150	51	270	31-406-PD	31-406R-PD	118	195
200	51	270	31-408-PD	31-408R-PD	147	248
XSR-VERY QUIET-GOOD SHOCK RESISTANCE-EASY ROLLING AND SWIVELLING						
63	35	80	16-62.5-XSR	16-62.5R-XSR	64	97
88	35	100	16-63.5-XSR	16-63.5R-XSR	77	121
100	35	125	16-64-XSR	16-64R-XSR	83	137
125	35	150	16-65-XSR	16-65R-XSR	102	162
150	38	170	31-76-XSR	31-76R-XSR	124	192
PSE AND XSE-LOWEST ROLLING EFFORT-GOOD SHOCK RESISTANCE-QUIET						
63	32	135	16-62.5-XSE	16-62.5R-XSE	64	97
75	35	230	31-73-PSE	31-73R-PSE	77	117
75	51	400	31-403-PSE	31-403R-PSE	83	121
88	32	160	16-63.5-XSE	16-63.5R-XSE	77	121
100	35	270	31-74-PSE	31-74R-PSE	89	141
100	51	400	31-404-PSE	31-404R-PSE	93	143
125	35	270	31-75-PSE	31-75R-PSE	102	168
125	51	450	31-405-PSE	31-405R-PSE	108	170
125	64	610	8-805-PSE	8-805R-PSE	118	181
150	35	270	31-76-PSE	31-76R-PSE	124	192
150	51	450	31-406-PSE	31-406R-PSE	118	195
150	64	680	8-806-PSE	8-806R-PSE	134	206
200	51	450	31-408-PSE	31-408R-PSE	147	248
200	64	750	8-808-PSE	8-808R-PSE	159	260
250	64	820	8-810-PSE	8-810R-PSE	185	311

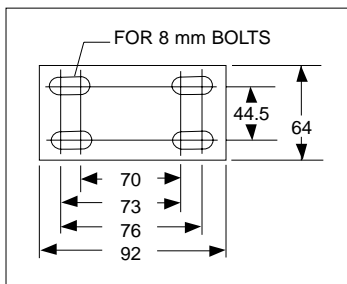

SWIVEL NO. 16 TOP PLATE

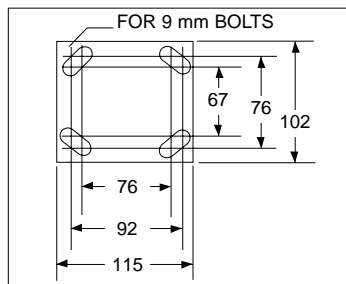

NO. 31 TOP PLATE

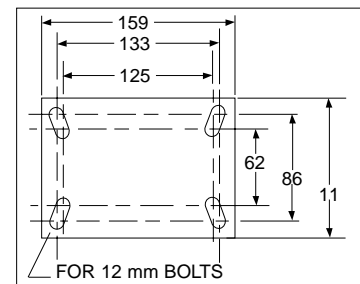

NO. 8 TOP PLATE

CARTWASHABLE™ and DATRYL™ are registered trademarks of Darcor Casters

WHEEL MATERIALS

D
W-76-XD

NEOPRENE
TREAD SYMBOL "D"
DUROMETER - SHORE 62 "A"

Superior for all floor surfaces and ergonomically designed for excellent mobility and resistance to wear. These quiet and easy rolling wheels are very shock absorbing, non-marking and will reject floor debris, roll over screws, metal or glass fragments, resin pellets and are non-staining. Darcor "VQ" very quiet ball bearings are standard in the 20 through 70 series. Precision ball bearings "P" are recommended in the 400 series. Sizes available 50 mm - 200 mm.

SE
W-406-PSE

SOLID ELASTOMER
TREAD SYMBOL "SE"
DUROMETER - SHORE 55 "D"

The solid Elastomer Wheel has set a new standard of performance for all applications where exceptional mobility is required. Ergonomically designed for medium loads (135 to 820 kg per wheel) the "SE" wheel is recommended for continuous use and "tow lines". It is also tolerant of a wide range of chemicals and is quiet, durable, shock-absorbing. For the ultimate mobility precision "P" bearings are recommended. The broad temperature range encourages use in freezers where ordinary wheels will seize and become immovable. The "SE" wheel is a real "BACK SAVER".

SR
W-76-XSR

NEOPRENE
TREAD SYMBOL "SR"
DUROMETER - SHORE 62 "A"

These wheels offer the same high quality as "D" wheels but with a low profile tread for easier swivelling and mobility.

U
W-406-TU

DARCOR URETHANE
TREAD SAYMBOL "U"
DUROMETER 95 "A"

Recommended for heavy loads and rough floors. Shock-absorbing. When fitted with tapered bearings, improves life and mobility.

WHEEL SELECTION GUIDE

FLOOR SURFACE

WHEEL MATERIAL	CARPET	LINOLEUM	WOOD	QUARRY TILE	CEMENT	ASPHALT	TERRAZZO	STEEL	ROUGH AND UNEVEN FLOORS
"D" NEOPRENE	X	X	X	X	X	X	X	X	X
"SR" SUPER ROLL NEOPRENE	X	X	X	X	X	X	X	X	X
"SE" SOLID ELASTOMER	X	X	X		X		X	X	
"U" DARCOR URETHANE		X	X	X	X	X	X	X	X
"CT" SEMI - STEEL					X			X	

OPERATING CONDITIONS

WHEEL MATERIAL	TEMPERATURE RANGE	MOBILITY	DURABILITY	FLOOR PROTECTION	CHEMICAL TOLERANCE	GLASS OR METAL CHIPS	WATER	STEAM
"D" NEOPRENE	-29 TO 150°C	EXCELLENT	EXCELLENT	EXCELLENT	EXCELLENT	EXCELLENT	EXCELLENT	EXCELLENT
"SR" SUPER ROLL NEOPRENE	-29 TO 150°C	EXCELLENT	EXCELLENT	EXCELLENT	EXCELLENT	EXCELLENT	EXCELLENT	EXCELLENT
"SE" SOLID ELASTOMER	-50 TO 110° C	EXCELLENT	EXCELLENT	EXCELLENT	EXCELLENT	FAIR	EXCELLENT	POOR
"U" DARCOR URETHANE	-40 TO 95°C	EXCELLENT	EXCELLENT	VERY GOOD	VERY GOOD	GOOD	GOOD	POOR
"CT" SEMI - STEEL	-40 TO 260°C	EXCELLENT	GOOD	POOR	GOOD	GOOD	POOR	POOR

SEE WHEEL SECTION, PAGE 44-56 for complete descriptions and sizes

ACCESSORIES

BRAKES - SWIVEL LOCKS - SWIVEL SEALS - THREAD GUARDS

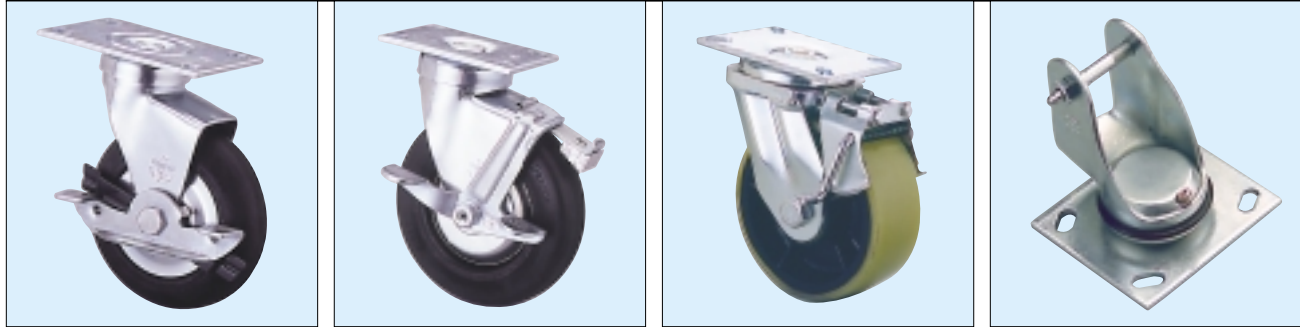

12-24B-XD

20 SERIES
SIDE BRAKE. Hardened spring. Steel brake pad for optimum braking on light loads.

16-65B-XD

60-70 SERIES
PIT BULL BRAKE. Specially designed metal pad riveted to the brake spring for use with neoprene wheels.

6-908B-TU

H700 - 900 SERIES
DISC BRAKE. Automotive brake pad material offers superior grip for heavy loads.

SWIVEL SEALS
OPTIONAL 60-70 SERIES
STANDARD 400-800 SERIES. Protects swivel from dirt, moisture and foreign material.



31-75B-PSE

60-70 SERIES
Wheel brake rubber pad riveted to spring steel engages against face of wheel.

31-406B-TD

400-800 SERIES
Cam action brake and swivel lock. Thick spring steel pad grips both the wheel and swivel.

31-76F-XD

SWIVEL LOCKS
Available from 40 series up. Foot operated for easy activation.

THREAD GUARDS
Standard on carpet masters through 400 series wheels. Protects against thread wrap up in axles and bearings.

BEARINGS

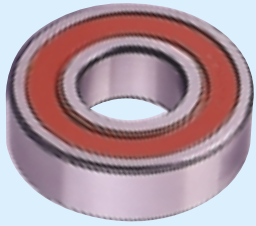

PRECISION SEALED BALL BEARING
DESIGNATION "P"
Offers least rolling resistance. Never requires lubrication. For medium loads, side thrust and high speeds.



MACHINED V. Q. (VERY QUIET) BALL BEARING
DESIGNATION "X"
Balls roll in a machined steel, case hardened raceway for least resistance. Slots allow grease into raceway.

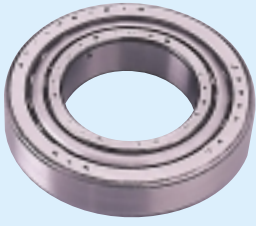

TAPERED ROLLER BEARING
DESIGNATION "Y"
For heavy loads, side thrust and high speeds.

ROLLER BEARING SPLIT SLEEVE OR DRAWN CUP
DESIGNATION "T"
Rollers turn on a hardened steel spanner bushing.



DELRIN™ BEARING
DESIGNATION "M"
A strong bearing material that resists corrosion. Ideal in wet applications. Requires lubrication.

SLEEVE BEARING (BUSHING)
No designation.
Case hardened steel. An inexpensive bearing for lighter loads.



AXLES



PLAIN AXLE
Standard in 20 series and all casters with sealed precision bearings. Also heavy duty series casters with grease fittings in wheel.

SELF TAPPING ALLEN HEAD AXLE.
Used with e2 and Carpet Master. Eliminates unsightly nut. Stops wear on shoes and nylon runs.

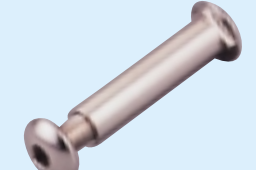

CROSS DRILLED AXLE
Standard on 60 and 70 series casters. Axle is drilled through center. Allows grease to flow into the bearing.

GREASE FITTING IN AXLE
Standard on 400 series optional 60 and 70 series. Cross drilled axle with zerk fitting in end. Fits standard grease guns.

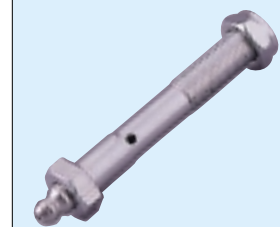

* DELRIN is a registered trademark of the Dupont Co.

APPLICATIONS



automobile

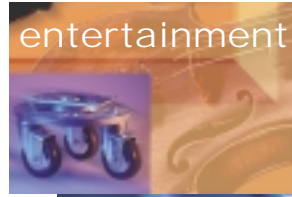

entertainment



freezer applications



food service



food & fish



hospital



At Darcor, we understand that every workplace is different, yet many share certain common requirements. We have set the pace of innovation by establishing industry application standards on four continents.

shock & vibration



materials handling



laundry



office applications



medical diagnostic



textile applications



In all of these application areas, Darcor remains successful by producing casters that feature ergonomic design, value, quality, flexibility, durability and performance.

DARCOR IS THE STANDARD BY WHICH ALL OTHER CASTERS ARE MEASURED

That is a bold statement – and one we stand behind totally. Just ask our customers. Talk to the many specialty manufacturers who have come to us for unique solutions to their caster needs. Speak with the international names in business and industry who have chosen Darcor casters to make their operations run more smoothly, more efficiently.

- What each of them will tell you is this: Darcor casters set the quality standards for the industry; Darcor is unmatched in its ability to deliver the perfect caster for specific applications. • We are aware our reputation rests on every caster we produce. That is why we maintain complete control over every aspect of their production in our own multifaceted manufacturing plant, featuring state-of-the-art in-house facilities and an expert, dedicated workforce.
- In this catalogue, you will find a complete range of the casters and wheels most frequently used by organizations like yours. You will also find something else: Casters and wheels which represent breakthrough advances that will markedly improve the function of your operations over the long term. • Research and development is one of our strengths. It allows us to actually anticipate the need for new types of casters in today's rapidly evolving manufacturing environment. We are able to respond with uniquely

designed products that blend ergonomic principles and advanced materials to improve bottom-line results and workplace conditions. • As a result, we have had more than our share of innovations so revolutionary they have redefined the function of casters in the workplace. Among those revolutionary innovations are the Neoprene wheel and the Solid Elastomer (SE) wheel. Check the specifications for these remarkable wheels and you will be amazed at their versatility and practicality. • When you choose a Darcor caster, you can rest easy, secure in the knowledge you have chosen the best. • We design to achieve a perfect match between need and caster. We engineer for strength, reliability and extended life. And we manufacture our casters under rigid controls that guarantee maximum long-life performance. • To ensure their integrity, we subject our casters to destruction tests under unbelievably hostile conditions. The trouble is, our casters are so good they sometimes wear out the test machinery before they wear out themselves. • So, while Darcor casters may have a higher initial price than others, they are actually the lowest-cost casters you can buy – because they are made to last.

- Remember our promise: Anything that moves will move better on a Darcor Caster. It's a promise you can profit from.

STEMS & OPTIONAL FITTINGS

MODEL #	DIAMETER X LENGTH	AVAILABLE ON CASTER SERIES					
		E2	53	20	30	60	70
CS125	1-1/4 square socket					60	
CS150	1-1/2 square socket					60	
CS150	1-5/8 round socket					60	
PIANO SOCKET	Use with OH Stem 1/2" x 1-1/8"			20	30	60	
JA	7/16" x 1-7/8"	E2	53	20			
LA	5/16" x 1" NC	E2	53	20			
LB	5/16" x 1-1/2" NC	E2	53	20			
LD	3-8" x 3/4" NC		53	20			
LE	3/8" x 1-1/4" NC		53	20			
LG	1/2" x 5/8" NC		53	20	30	60	
LH	1/2" x 1-1/2" NC		53	20	30	60	70
LK	1/2" x 2" NC		53	20	30	60	
LN	5/8 x 2" NC		53	20	30	60	70
LR	3/4" x 2" NC		53	20	30	60	70
OA	3/8" x 1"	E2	53	20			
OB	7/16" x 13/16"	E2	53	20			
OC	7/16" x 1-1/4"	E2	53	20			
OD	7/16" x 1-3/4"	E2	53	20			
OE	7/16" x 2"	E2	53	20			
OJ	7/16" x 1-1/2"				30	60	
OH	1/2" x 1-1/8"		53	20	30	60	
OM	9/16" x 4-1/2"		53	20			
OU	5/8" x 1-5/8"		53	20	30	60	70
OY	3/4" x 1-5/8"		53	20	30	60	70
OCC	13/16" x 2"				30	60	70
OEE	0.862" x 1-1/2"		53	20	30	60	
OGG	7/8" x 1-7/8"		53	20			
OHH	7/8" x 2"				30	60	70
OKK	1" x 1-5/8"		53	20	30	60	70
OKW	3/4" x 1-5/8" w/ .188 key				30	60	70
OXX	1.480 x 2-1/2					60	70
PBE	1/2" Pipe bushing		53	20	30	60	
PBF	3/4" Pipe bushing		53	20	30	60	70
PBG	1" Pipe bushing			20	30	60	70
PBH	1-1/4" Pipe bushing				30	60	
PCE	1/2" Pipe cap		53	20	30	60	
PCF	3/4" Pipe cap		53	20	30	60	70
PCG	1" Pipe cap				30	60	70
PCH	1-1/4" Pipe cap				30	60	
SA	Square 3/4" x 2"		53	20	30	60	
SB	Square 7/8" x 2-1/2"				30	60	70
SC	Square 7/8" x 2-1/2"			20	30	60	70
WSA	5/16" x 1-1/2" #3 Socket	E2					

PLASTIC SOCKETS USE WITH STEMS "OC" 7/16" X 1-1/4" "OD" 7/16" X 1-3/4"

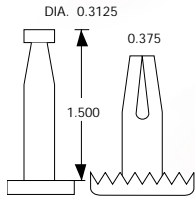

STEM FOR WOOD LEGS ETERNITY 2 ONLY PREFIX NUMBER "WSA" WITH #3 SOCKET

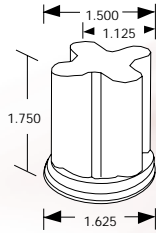

CS 158 SOCKET FITS 1-5/8" 16 GAUGE ROUND TUBING USE WITH "OU" STEM 5/8" x 1-5/8"

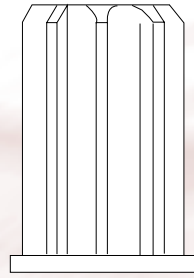

MODEL NUMBER	SIZE	FITS RD.I.D TUBE	FITS SQ.I.D. TUBE
RA	5/8"	5/8"	13/32"
RB	11/16"	11/16"	21/32"
RC	3/4"	3/4"	23/32"
RD	25/32"	25/32"	47/64"
RE	13/16"	13/16"	3/4"
RF	27/32"	27/32"	25/32"
RG	7/8"	7/8"	27/32"
RH	15/16"	15/16"	29/32"
RI	1"	1"	15/16"
RJ	1-1/16"	1-1/16"	1"
RK	1-1/8"	1-1/8"	1-3/64"
RL	1-3/16"	1-3/16"	1-7/64"

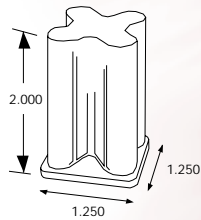

CS 125 SOCKET FITS 1-1/4" 14 GAUGE SQUARE TUBING SIZE WITH "OU" STEM 5/8" x 1-5/8"

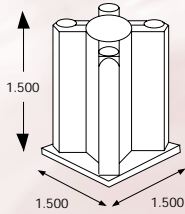

CS 150 SOCKET FITS 1-1/2" 18 GAUGE SQUARE TUBING USE WITH "OU" STEM 5/8" X 1-5/8"

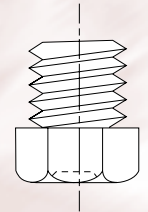

PIPE BUSHING PB STEM

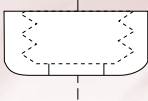

PIPE CAP PC STEM

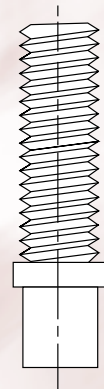

L SERIES

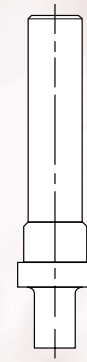

JA STEM

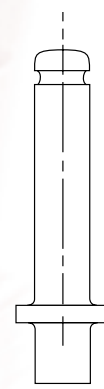

O SERIES

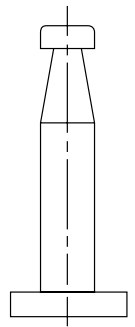

WSA STEM

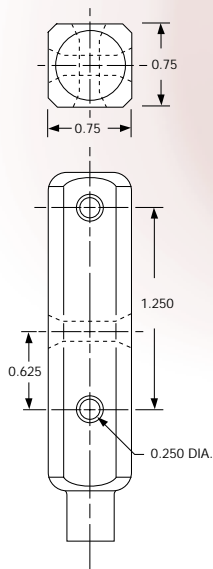

SA STEM

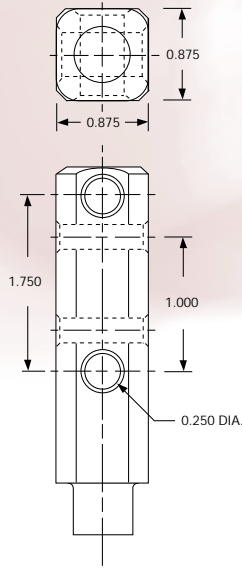

SB STEM

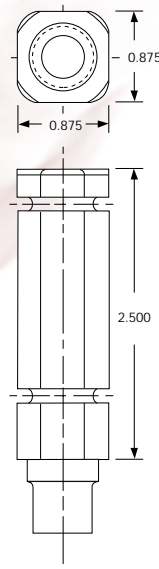

SC STEM

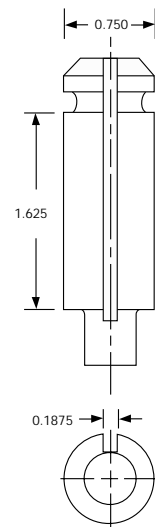

OKW STEM

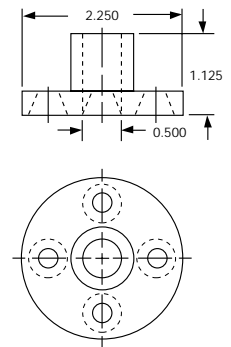

PIANO SOCKET

TOP PLATES - STANDARD AND OPTIONAL

Over the years, Darcor has manufactured many different sizes of top plates to eliminate problems when changing casters. These top plates are shown as options. Darcor can manufacture other top plates as required, provided the bolt hole centers do not interfere with the swivel raceway. Their cost is based on size and quantity.

TOP PLATE NUMBER	OVERALL SIZE		BOLT HOLE CENTERS (SEE DIAGRAMS)			MOUNTING BOLT SIZE	STANDARD ON SERIES	* OPTIONAL ON SERIES
	WIDTH	LENGTH	WIDTH	LENGTH	WIDTH			
	W x L		A - B		C - D		E	
3 (Swivel only)	1-3/8 x 1-7/8		13/16 x 1-3/8				3/16	E2
3	4 x 4		3 x 3				3/8 - 9/16	30-60-70-400
4 (Swivel only)	1-1/4 x 2-3/8		13/16 x 1-7/8				3/16	53-20
4	4 x 7		3 x 6				3/8	400
5 (Swivel only)	1-7/8 x 2-5/8		1-1/4 x 2				1/4	53-20
6 (Slotted)	5 x 7		3-3/8 x 5-1/4		4-1/8 x 6-1/8		1/2	700-900 400-800
7 (Swivel only)	2 x 2-1/8		1-1/2 x 1-1/2				1/4	53-20
8 (Slotted)	4-1/2 x 6-1/4		2-7/16 x 4-15/16		3-3/8 x 5-1/4		1/2	800 400
9	3-3/8 x 4-3/8		2-3/8 x 3-3/8				3/8 - 9/16	30-60-70-400
11 Swivel only	1-3/4 x 3		1 x 2-1/4				1/4	53-20
12 (Swivel-elongated holes)	2-1/2 x 3-5/8		1-3/4 x 2-3/4		x 2-7/8		3	5/16 20 53
12 (Rigid-elongated holes)	2-3/4 x 4		1-3/4 x 2-3/4		x 2-7/8		3	5/16 20
14	4 x 5		3 x 4				3/8	70-400
16 (Swivel-elongated holes)	2-1/2 x 3-5/8		1-3/4 x 2-3/4		x 2-7/8		3	5/16 30-60 70 Swivel & Rigid
16 (Rigid-elongated holes)	2-7/8 x 4-1/8		1-3/4 x 2-3/4		x 2-7/8		3	5/16 30-60
19 (Swivel only)	3-3/8 x 4-3/8		2-3/8 x 3-3/8				3/8	70 Swivel
22	3-7/8 x 6-1/4		2-7/16 x 4-7/8				3/8	400
31 (Slotted)	4 x 4-1/2		2-5/8 x 3		3 x 3-5/8		3/8	70-400 30-60
5-5000	6 x 10		4-3/4 x 8-3/4				1/2	5000
5-5200	6 x 12		4-1/2 x 10-1/2				1/2	5200
IS 2 (Slotted)	85mm x 100mm		45mm x 75mm		60mm x 80mm		9mm	30-60-70
IS 3 (Elongated)	110mm x 140mm		73mm x 105mm		80mm x	87mm	11mm	400 30-60-70

* All top plates available as options on other series are subject to special pricing.

DIMENSIONS

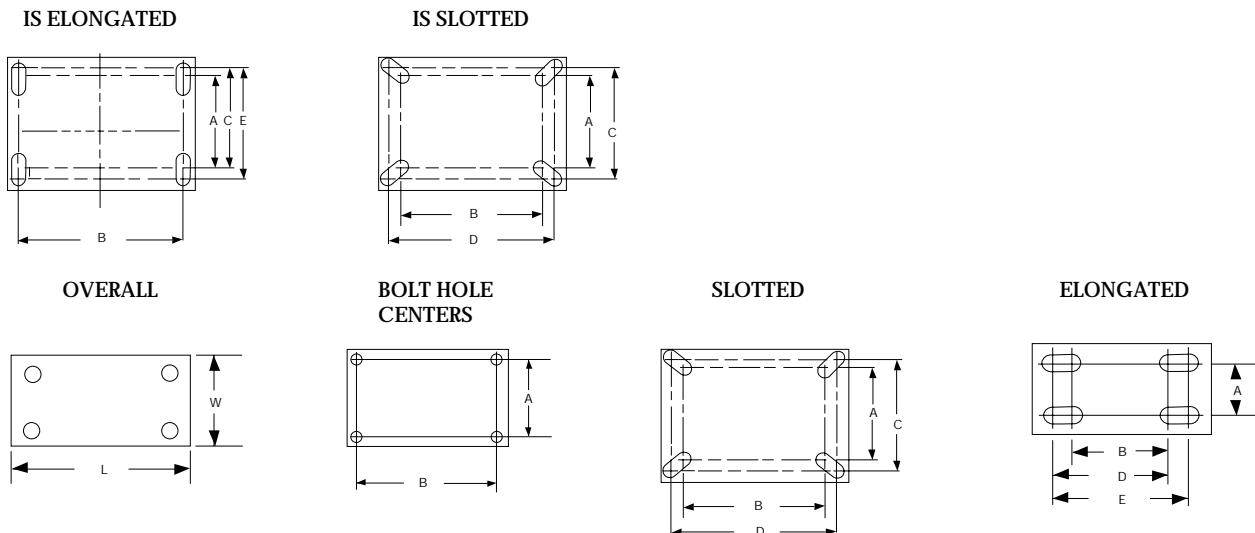

TUBING AND PIPE SIZES

Due to the large quantity of tubing sizes available, we have endeavoured over the years to manufacture stems to fit most standard sizes of tubing. We do not feel that expanding stems are the proper solution to these problems, as they have a tendency to wear and become loose. Our stems are equipped with a grip ring made from hardened spring steel to eliminate wear. Most of these can be installed at no extra charge where they apply to the series of caster. Please check optional fitting pages, for available sizes.

STANDARD IRON PIPE SIZES:

TUBING SIZE	"O" STEM SIZE REQUIRED
1" 16 GA Square Tubing	7/8 x 2
1" 16 GA Round Tubing	.862 x 1-1/2
1" 18 GA Round Tubing	.895 x 1-1/2
1-5/8" 16 GA Round Tubing	1.480 x 2-1/2
1-5/8" 16 GA Round Tubing	CS 158 Socket (5/8 x 1-5/8 Stem)
1-1/4" 14 GA Square Tubing	CS 125 Socket (5/8 x 1-5/8 Stem)
1-1/2" 18 GA Square Tubing	CS 150 Socket (5/8 x 1-5/8 Stem)

PIPE SIZE	INSIDE DIAMETER (DECIMAL) (FRACTION)		OUTSIDE DIAMETER
3/8"	.493	31/64"	.675
1/2"	.622	5/8"	.840
3/4"	.824	53/64"	1.050
1"	1.049	1-3/64"	1.315
1-1/4"	1.380	1-3/8"	1.660
1-1/2"	1.610	1-39/64"	1.900

CASTER MOUNTING CONFIGURATIONS

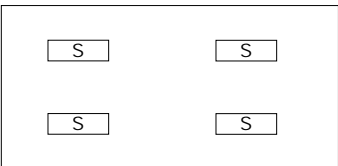

Four Swivel

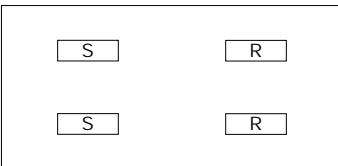

Two Swivel Two Rigid

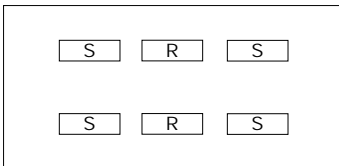

Four Swivel Two Rigid

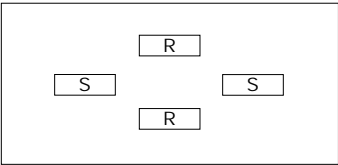

Diamond Mounting

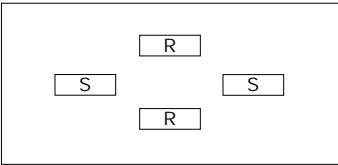

Tilt Mount

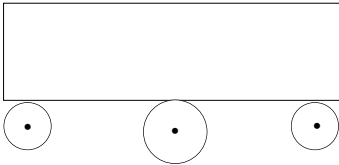

Tilt Mount Side View

OFFICE CHAIR CASTERS

Office Chair Casters by Darcor have earned a distinguished reputation for quality, based on years of consistently high performance and durability.

Their product stature is attributed to Darcor's dedication to meticulous research, design, engineering and testing. Widely used on office chairs, they are equally useful for many institutional applications including IV poles, overbed tables, nightstands and many other uses.

Darcor's innovative designs not only reduce wear and tear on the mechanism of chairs but increase the user's physical efficiency and comfort by reducing the strain of moving the chair during daily chores at workstations. Darcor's designs eliminate the frustrating experience of shoving and ploughing office chairs through carpets and over warped plastic mats.

The Carpet Master™ for carpeted floors, and the Eternity II for tile and linoleum floors - are synonymous with comfort. They have the qualities desired in a superior product, such as reliability, durability and unparalleled ease of movement. Both the Carpet Master™ and Eternity II incorporate the legendary Darcor double ball bearing swivel design, with two ball bearing races of equal diameter.

This ingenious design eliminates any possibility of binding, sticking, or sliding.

THE CARPET MASTER™



OC-53-XD

The Carpet Master rolls and swivels effortlessly, eliminating the need for unsightly and hazardous plastic mats. The silent, donut neoprene wheel with its soft resilient texture, rolls smoothly and quietly on all floor surfaces from carpet to quarry tile. The large swivel off-set and soft wheel reduces the stress on carpet fibers thus greatly extending carpet life. Carpet Master's are available in standard chrome and black matte finish. Also available with bright brass and brushed brass finish.

FEATURES

- 5/16" Axle
- 7/16" Rivet
- Double row ball bearing swivel, both raceways equal diameter. Ball bearings standard in wheel.
- Specially designed removable axle eliminates unsightly nut
- All swivel parts are case hardened
- Thread guards standard

ETERNITY II



OC-E2-XD

The Eternity II is recommended for all types of hard floors. The neoprene wheel will not mark or stain tile and has a remarkable inter-floor capability. Darcor casters are available with optional fittings, including top plates, stems and sockets. Eternity II has a standard chrome or black matte finish and is also available with a bright brass finish.

FEATURES

- 5/16" Axle
- 11/32" Rivet
- Double row ball bearing swivel, both raceways equal diameter. Ball bearings standard in wheel.
- Specially designed removable axle eliminates unsightly nut
- All swivel parts are case hardened

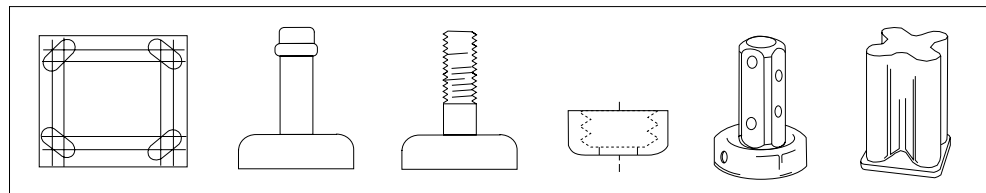

OPTIONAL TOP PLATES AND STEMS ARE AVAILABLE. SEE PAGES 14, 15, 16.

OFFICE CHAIR CASTERS

THE "CARPET MASTER"

WHEEL DIAMETER	TREAD WIDTH	LOAD CAP. /LBS	BEARING TYPE	FINISH	MODEL NUMBER	SWIVEL RADIUS	OVERALL HEIGHT
NEOPRENE - ERGONOMICALLY DESIGNED FOR EASY ROLLING							
3"	1"	100	BALL	CHROME	53-XD	3-1/8"	3-15/16"
3"	1"	100	BALL	BLACK MATTE	BM53-XD	3-1/8"	3-15/16"
3"	1"	100	BALL	BRUSHED BRASS	BR53-XD	3-1/8"	3-15/16"
3"	1"	100	BALL	ANTIQUÉ BRONZE	AB53-XD	3-1/8"	3-15/16"
HARD RUBBER - FOR DEEP PILE PLUSH OR SHAG CARPET							
3"	1"	125	BALL	CHROME	53-XH	3-1/8"	3-15/16"
3"	1"	125	BALL	BLACK MATTE	BM53-XH	3-1/8"	3-15/16"
3"	1"	125	BALL	BRUSHED BRASS	BR53-XH	3-1/8"	3-15/16"
3"	1"	125	BALL	ANTIQUÉ BRONZE	AB53-XH	3-1/8"	3-15/16"

THE "ETERNITY II"

WHEEL DIAMETER	TREAD WIDTH	LOAD CAP. /LBS	BEARING TYPE	FINISH	MODEL NUMBER	SWIVEL RADIUS	OVERALL HEIGHT
NEOPRENE - ERGONOMICALLY DESIGNED FOR EASY ROLLING							
2"	1"	75	BALL	CHROME	E2-XD	2"	2-3/4"
2"	1"	75	SLEEVE	CHROME	E2-D	2"	2-3/4"
2"	1"	75	BALL	BLACK MATTE	BME2-XD	2"	2-3/4"
2"	1"	75	SLEEVE	BLACK MATTE	BME2-D	2"	2-3/4"
2"	1"	75	BALL	BRIGHT BRASS	BBE2-XD	2"	2-3/4"
2"	1"	75	SLEEVE	BRIGHT BRASS	BBE2-D	2"	2-3/4"
HARD RUBBER							
2"	1"	75	BALL	CHROME	E2-XH	2"	2-3/4"
2"	1"	75	SLEEVE	CHROME	E2-H	2"	2-3/4"
2"	1"	75	BALL	BLACK MATTE	BME2-XH	2"	2-3/4"
2"	1"	75	SLEEVE	BLACK MATTE	BME2-H	2"	2-3/4"
2"	1"	75	BALL	BRIGHT BRASS	BBE2-XH	2"	2-3/4"
2"	1"	75	SLEEVE	BRIGHT BRASS	BBE2-H	2"	2-3/4"



12-24-XD



12-24R-XD



12-24B-XD

FEATURES

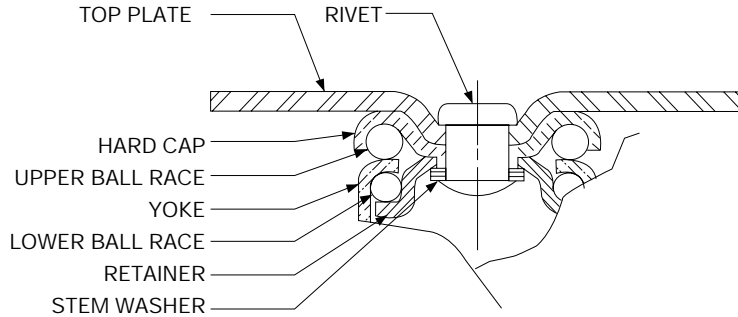

- 5/16" Axle
- 7/16" Rivet
- Double row ball bearing swivel. Both raceways equal diameter.
- Bright zinc finish
- All swivel parts case hardened to Rockwell 62C
- Thread guards standard on sizes larger than 2"

OPTIONS

- Brakes available on 3" and 4" models. Add letter "B".

INSTALLATIONS

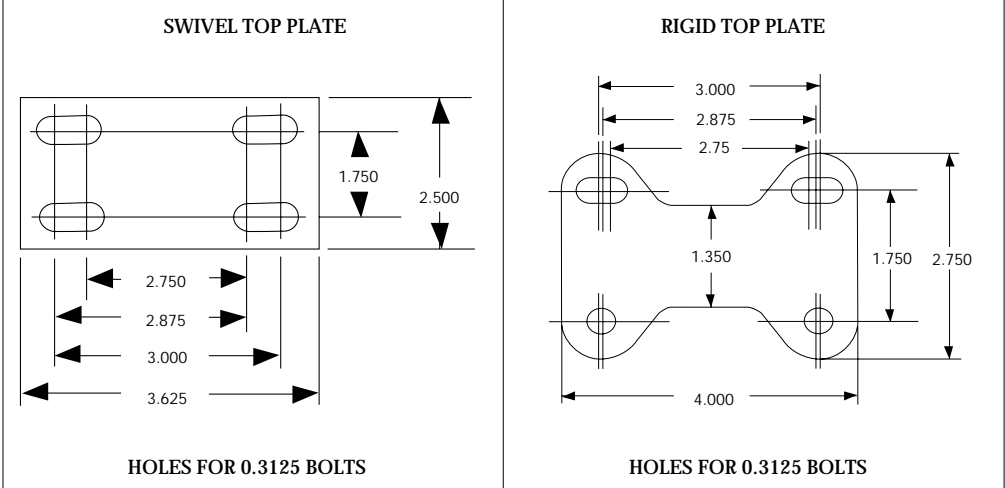

NO. 12 TOP PLATE (STANDARD ON 20 SERIES)

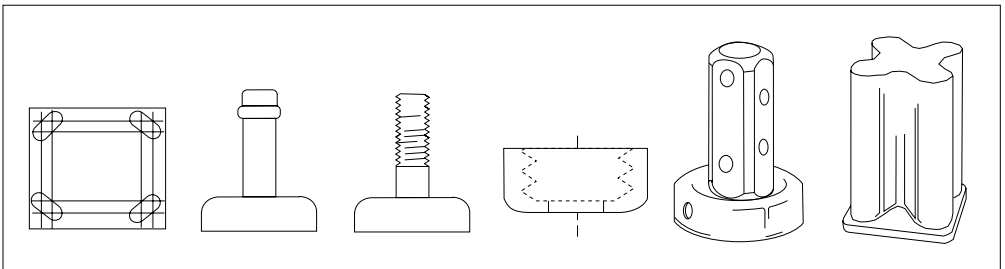

OPTIONAL TOP PLATES AND STEMS, PAGES 14, 15, 16.

20 SERIES

CAPACITY: 75 - 125 LBS PER CASTER

WHEEL DIAMETER	TREAD WIDTH	LOAD CAP./LBS	BEARING TYPE	SWIVEL MODEL	RIGID MODEL	SWIVEL RADIUS	OVERALL HEIGHT
NEOPRENE - SOFT, NON MARKING AND NON STAINING - USED ON ANY FLOOR SURFACE - ERGO*							
2"	1"	125	BALL	12-22-XD	12-22R-XD	2"	3-1/8"
2"	1"	75	SLEEVE	12-22-D	12-22R-D	2"	3-1/8"
3"	1"	125	BALL	12-23-XD	12-23R-XD	3"	4-1/4"
3"	1"	75	SLEEVE	12-23-D	12-23R-D	3"	4-1/4"
4"	1"	125	BALL	12-24-XD	12-24R-XD	3-3/8"	5-1/4"
4"	1"	75	SLEEVE	12-24-D	12-24R-D	3-3/16"	5-1/4"
5"	1"	125	BALL	12-25-XD	12-25R-XD	3-7/8"	6-1/4"
5"	1"	75	SLEEVE	12-25-D	12-25R-D	3-7/8"	6-1/4"
NEOPRENE SUPER ROLL - SOFT LOW PROFILE TREAD FOR EXTREMELY EASY ROLLING AND SWIVELING - ERGO*							
2-1/2"	1"	125	BALL	12-22.5-XSR	12-22.5R-XSR	2-1/8"	3-5/8"
2-1/2"	1"	75	SLEEVE	12-22.5-SR	12-22.5R-SR	2-1/8"	3-5/8"
SEMI-STEEL - CROWNED SEMI-STEEL CASTING OF A CLOSE-GRAINED CAST IRON							
2"	1"	100	SLEEVE	12-22-CI	12-22R-CI	2"	3-1/8"
2-1/2"	1"	125	SLEEVE	12-22.5-CI	12-22.5R-CI	2-1/8"	3-5/8"
RUBBER - SEMI-RESILIENT RUBBER MATERIAL							
2"	1"	75	SLEEVE	12-22-K	12-22R-K	2"	3-1/8"
2-1/2"	1"	75	SLEEVE	12-22.5-K	12-22.5R-K	2-1/8"	3-5/8"
3"	1"	75	SLEEVE	12-23-K	12-23R-K	3"	4-1/4"
4"	1"	75	SLEEVE	12-24-K	12-24R-K	3-3/8"	5-1/4"
HARD RUBBER - HARD SYNTHETIC RUBBER MATERIAL NOT AFFECTED BY OIL OR GREASE							
2"	1"	100	BALL	12-22-XH	12-22R-XH	2"	3-1/8"
2"	1"	100	SLEEVE	12-22-H	12-22R-H	2"	3-1/8"
2-1/2"	1"	125	SLEEVE	12-22.5-H	12-22.5R-H	2-1/8"	3-5/8"
3"	1"	125	SLEEVE	12-23-H	12-23R-H	3"	4-1/4"
4"	1"	125	SLEEVE	12-24-H	12-24R-H	3-3/8"	5-1/4"

* Ergonomically designed for easy rolling.

30 SERIES/TWIN WHEEL CASTERS

CAPACITY: 300 – 400 LBS PER CASTER



16-32-XD



16-32R-XD



16-32.5-XSR



16-32.5R-XSR

FEATURES

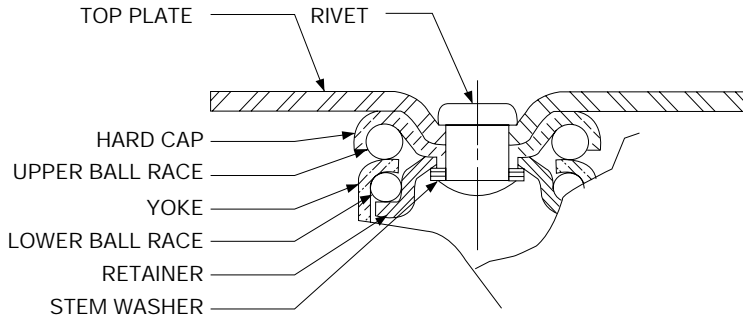

- 5/16" Axle
- 1/2" Rivet
- Double row ball bearing swivel. Both raceways equal diameter
- Bright chrome finish
- All swivel parts case hardened to Rockwell 62C
- Thread guards standard on 2-1/2" wheels

INSTALLATIONS

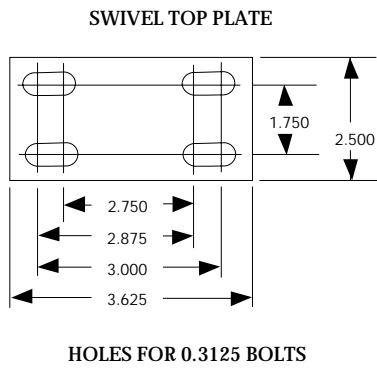

HOLES FOR 0.3125 BOLTS

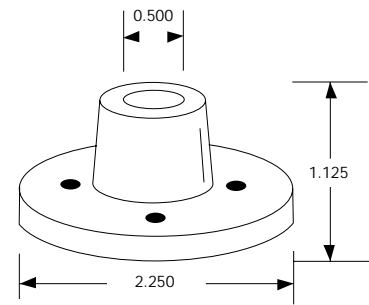

NO. 16 TOP PLATE

PIANO SOCKET SYMBOL P.S. "0" STEM 1/2" X 1-1/8"

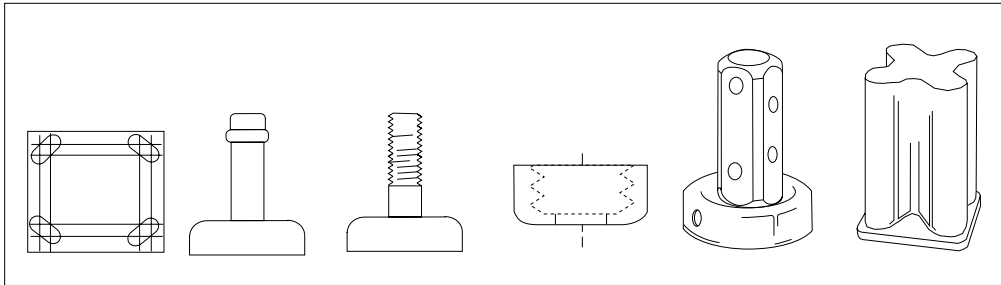

OPTIONAL TOP PLATES AND STEMS, PAGES 14, 15, 16

WHEEL DIA.	TREAD WIDTH	LOAD CAP./LBS	BEARING TYPE	SWIVEL MODEL	RIGID MODEL	SWIVEL RADIUS	OVERALL HEIGHT
NEOPRENE SUPER ROLL - ERGO*							
2"	1"	300	BALL	16-32-XD	16-32R-XD	2-3/8"	3-3/8"
2-1/2"	1"	300	BALL	16-32.5-XSR	16-32.5R-XSR	2-5/8"	3-7/8"
HARD RUBBER							
2"	1"	400	BALL	16-32-XH	16-32R-XH	2-3/8"	3-3/8"
2-1/2"	1"	400	BALL	16-32.5-XH	16-32.5R-XH	2-5/8"	3-7/8"

* Ergonomically designed for easy rolling.

OTHER SIZES (3", 4" AND 5") AVAILABLE ON SPECIAL ORDER.



Tel • 1-416-255-8563
Fax • 1-416-251-6117



60 SERIES

CAPACITY: 150 — 400 LBS PER CASTER



16-65-XD

FEATURES

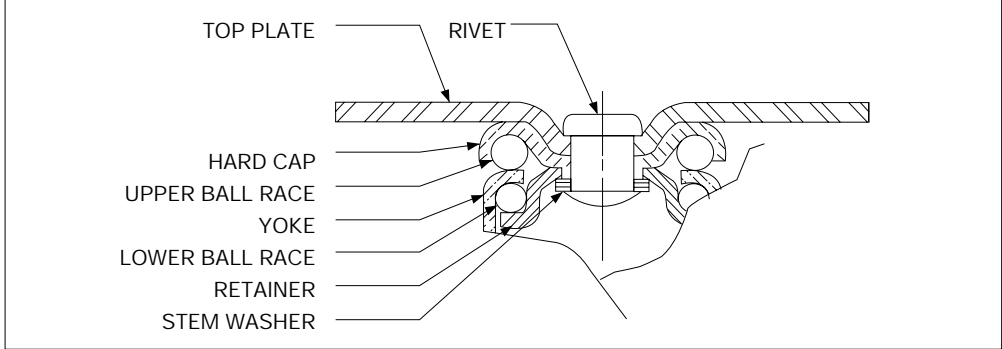

16-65R-XD

- 3/8" Axle
- 1/2" Rivet
- Double row ball bearing swivel. Both raceways equal diameter
- Bright zinc finish
- All swivel parts case hardened to Rockwell 62C
- Thread guards standard on wheels

OPTIONS

- Brakes available, 3", 3.5", 4", and 5" models. Add letter "B".
- Four position swivel locks. Add letter "F". Not available on stem casters.
- Brakes and swivel locks cannot be combined on the same caster.
- Swivel seals with zerk in swivel and axle. Add letter "S".
- Zerk in axle only. Add letter "G".



16-65B-XSR

INSTALLATIONS

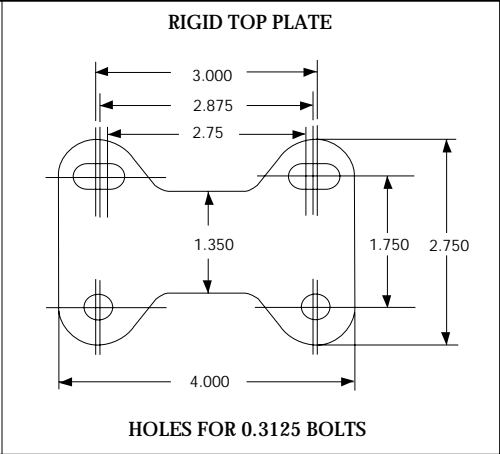
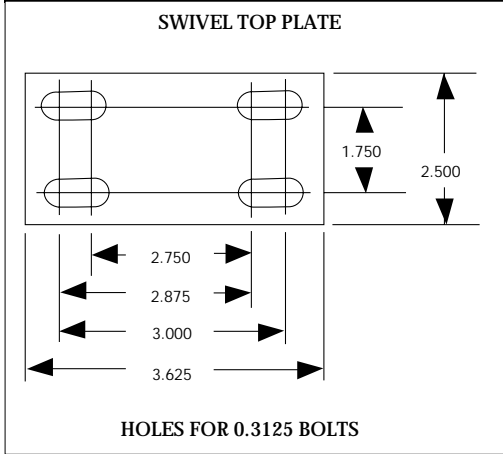

NO. 16 TOP PLATE (STANDARD ON 60 SERIES)

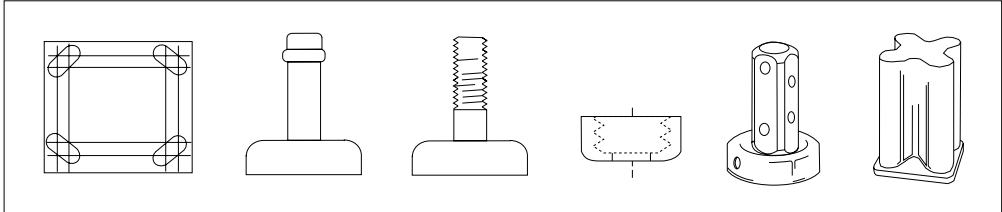

OPTIONAL TOP PLATES AND STEMS ARE AVAILABLE. SEE PAGES 14, 15, 16.

60 SERIES

CAPACITY: 150 – 400 LBS PER CASTER

WHEEL DIAMETER	TREAD WIDTH	LOAD CAP./LBS	BEARING TYPE	SWIVEL MODEL	RIGID MODEL	SWIVEL RADIUS	OVERALL HEIGHT
NEOPRENE - NON MARKING AND NON STAINING - USED ON ANY FLOOR SURFACE - ERGO*							
3"	1-3/8"	200	BALL	16-63-XD	16-63R-XD	2-3/4"	4-5/16"
3-1/2"	1-3/8"	200	BALL	16-63.5-XD	16-63.5R-XD	3"	4-3/4"
4"	1-3/8"	225	BALL	16-64-XD	16-64R-XD	3-1/4"	5-5/16"
5"	1-3/8"	250	BALL	16-65-XD	16-65R-XD	4"	6-5/16"
NEOPRENE - SUPER ROLL SOFT LOW PROFILE TREAD FOR EXTREMELY EASY ROLLING AND SWIVELING - ERGO*							
2-1/2"	1-3/8"	200	BALL	16-62.5-XSR	16-62.5R-XSR	2-1/2"	3-13/16"
3-1/2"	1-3/8"	225	BALL	16-63.5-XSR	16-63.5R-XSR	3"	4-3/4"
4"	1-3/8"	275	BALL	16-64-XSR	16-64R-XSR	3-1/4"	5-5/16"
5"	1-3/8"	325	BALL	16-65-XSR	16-65R-XSR	4"	6-5/16"
SOLID ELASTOMER-VERY LOW STARTING AND ROLLING RESISTANCE - ERGO*							
2-1/2"	1-1/4"	300	BALL	16-62.5-XSE	16-62.5R-XSE	2-1/2"	3-13/16"
3-1/2"	1-1/4"	350	BALL	16-63.5-XSE	16-63.5R-XSE	3"	4-3/4"
SEMI-STEEL - CROWNED SEMI-STEEL CASTING							
2-1/2"	1-1/4"	400	SLEEVE	16-62.5-CI	16-62.5R-CI	2-1/2"	3-13/16"
3"	1-3/8"	400	SLEEVE	16-63-CI	16-63R-CI	2-3/4"	4-5/16"
3-1/2"	1-1/4"	400	SLEEVE	16-63.5-CI	16-63.5R-CI	3"	4-3/4"
4"	1-3/8"	400	SLEEVE	16-64-CI	16-64R-CI	3-1/4"	5-5/16"
5"	1-3/8"	400	SLEEVE	16-65-CI	16-65R-CI	4"	6-5/16"
V-GROOVED - ECONOMICAL HANDLING OF HEAVY LOADS ON ANGLE TRACK							
3"	1-1/4"	300	SLEEVE	16-63-CV	16-63R-CV	2-3/4"	4-5/16"
RUBBER - SEMI-RESILIENT RUBBER MATERIAL							
3-1/2"	1-3/8"	150	SLEEVE	16-63.5-K	16-63.5R-K	3"	4-3/4"
4"	1-3/8"	175	SLEEVE	16-64-K	16-64R-K	3-1/4"	5-5/16"
5"	1-3/8"	175	SLEEVE	16-65-K	16-65R-K	4"	6-5/16"
HARD RUBBER - HARD SYNTHETIC RUBBER MATERIAL NOT AFFECTED BY OIL OR GREASE							
3"	1-3/8"	350	SLEEVE	16-63-H	16-63R-H	2-3/4"	4-5/16"
3-1/2"	1-3/8"	375	SLEEVE	16-63.5-H	16-63.5R-H	3"	4-3/4"
4"	1-3/8"	400	SLEEVE	16-64-H	16-64R-H	3-1/4"	5-5/16"
5"	1-3/8"	400	SLEEVE	16-65-H	16-65R-H	4"	6-5/16"

* Ergonomically designed for easy rolling.

SLEEVE - M - BEARINGS AVAILABLE FOR WET APPLICATIONS.

70 SERIES

CAPACITY: 225 — 600 LBS PER CASTER



31-76-XSR



31-76R-XD



31-76B-XD



31-76-PSE

FEATURES

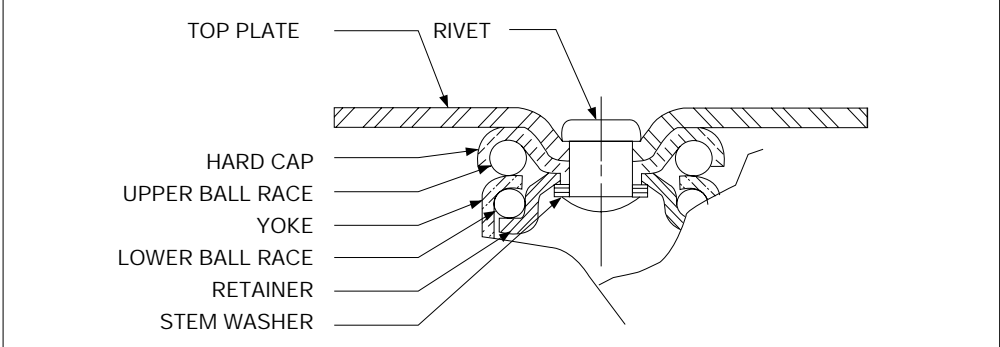

- 3/8" Axle
- 9/16" Rivet.
- Double row ball bearing swivel. Both raceways equal diameter
- Bright zinc finish
- All swivel parts case hardened to Rockwell 62C
- Thread guards standard on wheels

OPTIONS

- Brakes available, on 4", 5", and 6" models. Add letter "B"
- Four Position Swivel locks. Add letter "F".
- Swivel seals with zerk in swivel and axle. Add letter "S".
- Zerk in axle only. Add letter "G".

INSTALLATIONS

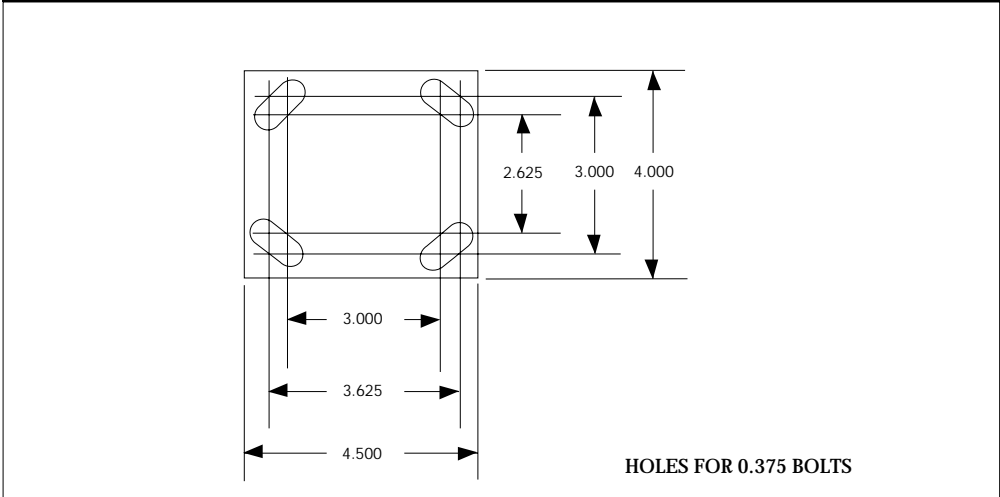

NO. 31 (STANDARD ON 70 SERIES)
 OPTIONAL TOP PLATES AVAILABLE, SEE PAGE 16.

70 SERIES

CAPACITY: 225 – 600 LBS PER CASTER

WHEEL DIAMETER	TREAD WIDTH	LOAD CAP./LBS	BEARING TYPE	SWIVEL MODEL	RIGID MODEL	SWIVEL RADIUS	OVERALL HEIGHT
NEOPRENE - SOFT NON MARKING AND NON STAINING — USED ON ANY FLOOR SURFACE - ERGO*							
3"	1-3/8"	225	BALL	31-73-XD	31-73R-XD	3"	4-5/8"
4"	1-3/8"	250	BALL	31-74-XD	31-74R-XD	3-1/2"	5-9/16"
5"	1-3/8"	275	BALL	31-75-XD	31-75R-XD	4"	6-5/8"
6"	1-5/8"	300	BALL	31-76-XD	31-76R-XD	4-7/8"	7-9/16"
NEOPRENE SUPER ROLL - SOFT LOW PROFILE TREAD FOR EASY ROLLING AND SWIVELING - ERGO*							
4"	1-3/8"	300	BALL	31-74-XSR	31-74R-XSR	3-1/2"	5-9/16"
5"	1-3/8"	350	BALL	31-75-XSR	31-75R-XSR	4"	6-5/8"
6"	1-1/2"	400	BALL	31-76-XSR	31-76R-XSR	4-7/8"	7-9/16"
SOLID ELASTOMER - VERY LOW STARTING AND ROLLING RESISTANCE - ERGO*							
3"	1-3/8"	500	PRECISION BALL	31-73-PSE	31-73R-PSE	3"	4-5/8"
4"	1-3/8"	600	PRECISION BALL	31-74-PSE	31-74R-PSE	3-1/2"	5-9/16"
5"	1-3/8"	600	PRECISION BALL	31-75-PSE	31-75R-PSE	4"	6-5/8"
6"	1-3/8"	600	PRECISION BALL	31-76-PSE	31-76R-PSE	4-7/8"	7-9/16"
URETHANE - FOR HEAVY LOADS AND ROUGH FLOOR CONDITIONS - ERGO*							
4"	1-3/8"	600	ROLLER	31-74-TU	31-74R-TU	3-1/2"	5-9/16"
5"	1-3/8"	600	ROLLER	31-75-TU	31-75R-TU	4"	6-5/8"
6"	1-3/8"	600	ROLLER	31-76-TU	31-76R-TU	4-7/8"	7-9/16"
SEMI-STEEL - CROWNED SEMI-STEEL CASTING							
3"	1-3/8"	500	SLEEVE	31-73-CI	31-73R-CI	3"	4-5/8"
3"	1-3/8"	500	ROLLER	31-73-TCI	31-73R-TCI	3"	4-5/8"
4"	1-3/8"	600	SLEEVE	31-74-CI	31-74R-CI	3-1/2"	5-9/16"
4"	1-3/8"	600	ROLLER	31-74-TCI	31-74R-TCI	3-1/2"	5-9/16"
5"	1-3/8"	600	SLEEVE	31-75-CI	31-75R-CI	4"	6-5/8"
5"	1-3/8"	600	ROLLER	31-75-TCI	31-75R-TCI	4"	6-5/8"
6"	1-3/8"	600	SLEEVE	31-76-CI	31-76R-CI	4-7/8"	7-9/16"
V-GROOVED - ECONOMICAL HANDLING OF HEAVY LOADS ON ANGLE TRACK							
4"	1-3/8"	500	ROLLER	31-74-TCV	31-74R-TCV	3-1/2"	5-9/16"
5"	1-1/2"	600	ROLLER	31-75-TCV	31-75R-TCV	4"	6-5/8"
HARD RUBBER - HARD SYNTHETIC RUBBER MATERIAL NOT AFFECTED BY OIL OR GREASE							
3"	1-3/8"	500	SLEEVE	31-73-H	31-73R-H	3"	4-5/8"
4"	1-3/8"	550	SLEEVE	31-74-H	31-74R-H	3-1/2"	5-9/16"
5"	1-3/8"	600	SLEEVE	31-75-H	31-75R-H	4"	6-5/8"
6"	1-3/8"	600	SLEEVE	31-76-H	31-76R-H	4-7/8"	7-9/16"

* Ergonomically designed for easy rolling.

SLEEVE - M - BEARINGS AVAILABLE FOR WET APPLICATIONS.

400 SERIES

CAPACITY: 400-1000 LBS PER CASTER



31-406-PSE



31-406R-PD



31-406B-PD



31-406F-PSE

FEATURES

- KING BOLT
- TOP PLATE
- HARD CAP
- UPPER BALL RACE
- UPPER SWIVEL SEAL
- YOKE
- LOWER BALL RACE
- RETAINER
- STEM WASHER
- LOWER SEAL
- ZERK FITTING

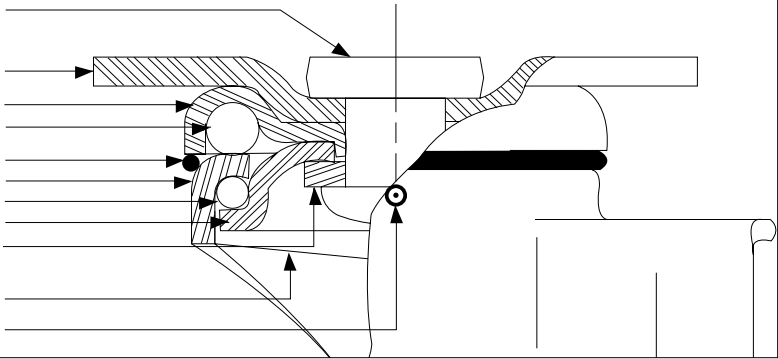

- 1/2" Axle
- 3/4" Rivet
- Double row ball bearing swivel. Both raceways equal diameter
- Standard with swivel seals and grease fittings in swivel and axle
- Bright zinc finish
- All swivel parts case hardened to Rockwell 62C
- Thread guards standard on wheels

OPTIONS

- Brakes, locks wheel and swivel. Available on 5", 6" and 8" models. Add letter "B".
- Four position swivel locks. Add letter "F".
- Brakes and swivel locks cannot be combined on the same caster.

INSTALLATIONS

NO. 31 TOP PLATE
(STANDARD ON 400 SERIES)

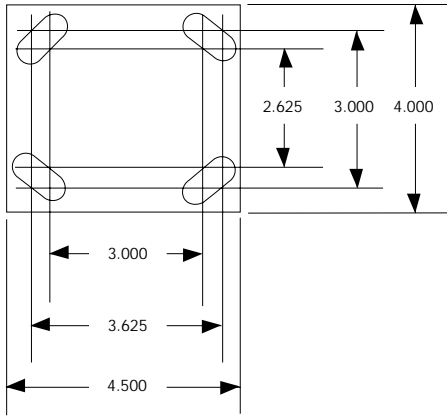

HOLES FOR 0.375 BOLTS

OPTIONAL TOP PLATES

- NO. 4 TOP PLATE
- NO. 1S3 TOP PLATE
- NO. 6 TOP PLATE
- NO. 8 TOP PLATE
- NO. 14 TOP PLATE
- NO. 22 TOP PLATE
- SEE PAGE 16 FOR DIMENSIONS

400 SERIES

CAPACITY: 400 – 1000 LBS PER CASTER

WHEEL DIAMETER	TREAD WIDTH	LOAD CAP./LBS	BEARING TYPE	SWIVEL MODEL	RIGID MODEL	SWIVEL RADIUS	OVERALL HEIGHT
NEOPRENE - NON MARKING AND NON STAINING - USED ON ANY FLOOR SURFACE - ERGO*							
4"	2"	400	ROLLER	31-404-TD	31-404R-TD	3-5/8"	5-5/8"
4"	2"	500	PRECISION BALL	31-404-PD	31-404R-PD	3-5/8"	5-5/8"
5"	2"	450	ROLLER	31-405-TD	31-405R-TD	4-1/4"	6-11/16"
5"	2"	550	PRECISION BALL	31-405-PD	31-405R-PD	4-1/4"	6-11/16"
6"	2"	500	ROLLER	31-406-TD	31-406R-TD	4-5/8"	7-11/16"
6"	2"	600	PRECISION BALL	31-406-PD	31-406R-PD	4-5/8"	7-11/16"
8"	2"	500	ROLLER	31-408-TD	31-408R-TD	5-3/4"	9-3/4"
8"	2"	600	PRECISION BALL	31-408-PD	31-408R-PD	5-3/4"	9-3/4"
SOLID ELASTOMER - VERY LOW STARTING AND ROLLING RESISTANCE - ERGO*							
3"	2"	900	PRECISION BALL	31-403-PSE	31-403R-PSE	3-1/4"	4-3/4"
4"	2"	900	PRECISION BALL	31-404-PSE	31-404R-PSE	3-5/8"	5-5/8"
5"	2"	1000	PRECISION BALL	31-405-PSE	31-405R-PSE	4-1/4"	6-11/16"
6"	2"	1000	PRECISION BALL	31-406-PSE	31-406R-PSE	4-5/8"	7-11/16"
8"	2"	1000	PRECISION BALL	31-408-PSE	31-408R-PSE	5-3/4"	9-3/4"
URETHANE - FOR HEAVY LOADS AND ROUGH FLOOR CONDITIONS - ERGO*							
3-1/2"	2"	800	ROLLER	31-403.5-TU	31-403.5R-TU	3-1/2"	5-1/16"
4"	2"	900	ROLLER	31-404-TU	31-404R-TU	3-5/8"	5-5/8"
5"	2"	1000	ROLLER	31-405-TU	31-405R-TU	4-1/4"	6-11/16"
6"	2"	1000	ROLLER	31-406-TU	31-406R-TU	4-5/8"	7-11/16"
8"	2"	1000	ROLLER	31-408-TU	31-408R-TU	5-3/4"	9-3/4"
V-GROOVED - ECONOMICAL HANDLING OF HEAVY LOADS ON ANGLE TRACK							
4"	2"	800	ROLLER	31-404-TCV	31-404R-TCV	3-5/8"	5-5/8"
5"	2"	1000	ROLLER	31-405-TCV	31-405R-TCV	4-1/4"	6-11/16"
SEMI - STEEL - CROWNED SEMI - STEEL CASTING							
3"	1-7/8"	900	ROLLER	31-403-TCI	31-403R-TCI	3-1/4"	4-3/4"
4"	1-7/8"	1000	ROLLER	31-404-TCI	31-404R-TCI	3-5/8"	5-5/8"
5"	1-7/8"	1000	ROLLER	31-405-TCI	31-405R-TCI	4-1/4"	6-11/16"
6"	1-7/8"	1000	ROLLER	31-406-TCI	31-406R-TCI	4-5/8"	7-11/16"
8"	1-7/8"	1000	ROLLER	31-408-TCI	31-408R-TCI	5-3/4"	9-3/4"

* Ergonomically designed for easy rolling.

DELRIN™ BEARINGS AVAILABLE IN NEOPRENE (D) AND SOLID ELASTOMER "SE" WHEELS. SUBSTITUTE LETTER "M" FOR LETTER "P"

800 SERIES

CAPACITY: 1350-1800 LBS PER CASTER



8-808-TU



8-808R-TCI



8-810F-PSE

FEATURES

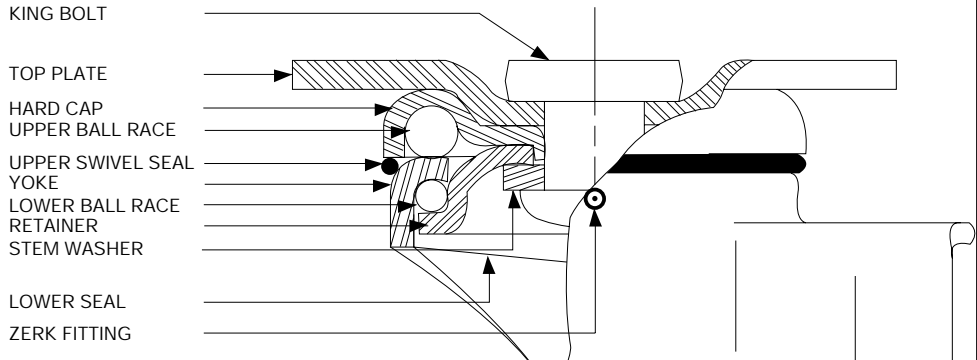

- 3/4" Axle
- 1" King bolt
- Double row ball bearing swivel
- Both raceways equal diameter
- Standard with swivel seals and grease fittings in swivel and axle
- Bright zinc finish
- All swivel parts case hardened to Rockwell 62C

OPTIONS

- Brakes, locks wheel and swivel. Available on 6", 8" and 10" models. Add letter "B".
- Four position swivel locks. Add letter "F".
- Brakes and swivel locks cannot be combined on the same caster.

INSTALLATIONS

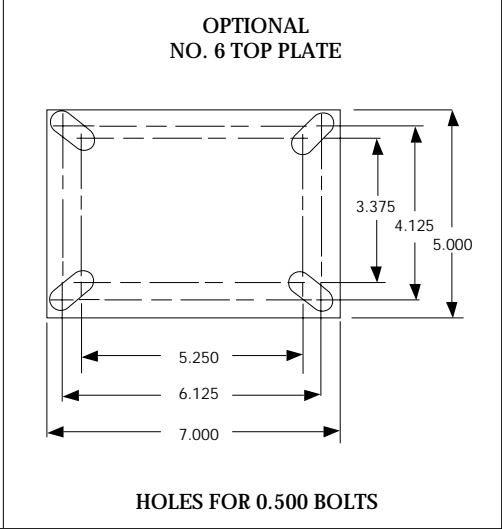
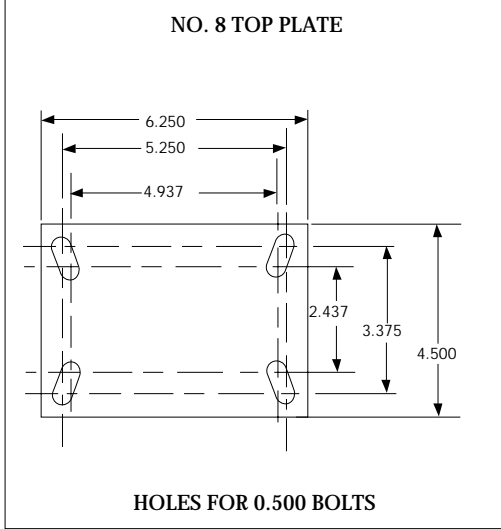

800 SERIES

CAPACITY: 1350-1800 LBS. PER CASTER

WHEEL DIAMETER	TREAD WIDTH	LOAD CAP./LBS	BEARING TYPE	SWIVEL MODEL	RIGID MODEL	SWIVEL RADIUS	OVERALL HEIGHT
SOLID ELASTOMER - VERY LOW STARTING AND ROLLING RESISTANCE - ERGO*							
5"	2-1/2"	1350	PRECISION BALL	8-805-PSE	8-805R-PSE	4-5/8"	7-1/8"
6"	2-1/2"	1500	PRECISION BALL	8-806-PSE	8-806R-PSE	5-1/8"	8-1/8"
8"	2-1/2"	1650	PRECISION BALL	8-808-PSE	8-808R-PSE	6-1/8"	10-1/4"
10"	2-1/2"	1800	PRECISION BALL	8-810-PSE	8-810R-PSE	7-1/8"	12-1/4"
URETHANE - FOR HEAVY LOADS AND ROUGH FLOOR CONDITIONS - ERGO*							
6"	2-1/4"	1500	ROLLER	8-806-TU	8-806R-TU	5-1/8"	8-1/8"
8"	2-1/2"	1800	ROLLER	8-808-TU	8-808R-TU	6-1/8"	10-1/4"
SEMI-STEEL - CROWNED SEMI-STEEL CASTING							
5"	2-1/4"	1500	ROLLER	8-805-TCI	8-805R-TCI	4-5/8"	7-1/8"
6"	2-1/4"	1700	ROLLER	8-806-TCI	8-806R-TCI	5-1/8"	8-1/8"
8"	2-1/4"	1800	ROLLER	8-808-TCI	8-808R-TCI	6-1/8"	10-1/4"
10"	2-1/4"	1800	ROLLER	8-810-TCI	8-810R-TCI	7-1/8"	12-1/4"
V-GROOVED - ECONOMICAL HANDLING OF HEAVY LOADS ON ANGLE TRACK							
6"	2-1/2"	1500	ROLLER	8-806-TCV	8-806R-TCV	5-1/8"	8-1/8"
8"	2-1/2"	1800	ROLLER	8-808-TCV	8-808R-TCV	6-1/8"	10-1/4"

* Ergonomically designed for easy rolling.

700 SERIES

CAPACITY: 1350-2200 LBS. PER CASTER



6-708-TU



6-708R-TU

FEATURES

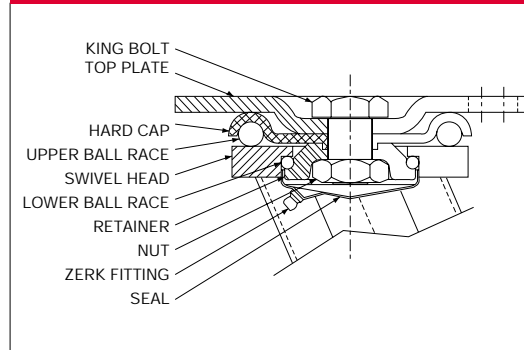

- 3/4" Axle
- 7/8" Grade 8 King bolt
- Double row ball bearing swivel
- Grease fittings in swivel and axle
- Bright zinc finish
- All swivel parts case hardened to Rockwell 62C

OPTIONS

- Brakes available. Add letter "B".
- Four Position Swivel locks. Add letter "F"
- Brakes and swivel locks cannot be combined on the same caster.

INSTALLATION

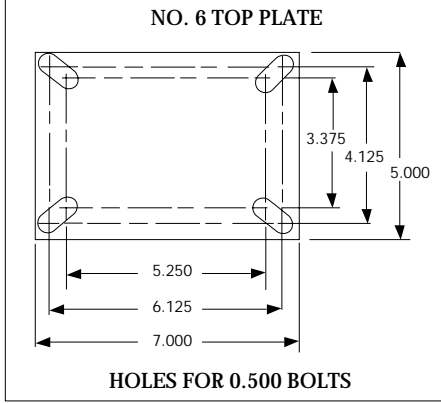

WHEEL DIAMETER	TREAD WIDTH	LOAD CAP./LBS	BEARING TYPE	SWIVEL MODEL	RIGID MODEL	SWIVEL RADIUS	OVERALL HEIGHT
SOLID ELASTOMER - VERY LOW STARTING AND ROLLING RESISTANCE - ERGO*							
5"	2-1/2"	1350	PRECISION BALL	6-705-PSE	6-705R-PSE	4-5/8"	7-1/8"
6"	2-1/2"	1500	PRECISION BALL	6-706-PSE	6-706R-PSE	5-1/8"	8-1/8"
8"	2-1/2"	1650	PRECISION BALL	6-708-PSE	6-708R-PSE	6-1/8"	10-1/4"
10"	2-1/2"	1800	PRECISION BALL	6-710-PSE	6-710R-PSE	7-1/8"	12-1/4"
SEMI-STEEL - CROWNED SEMI-STEEL CASTING							
5"	2-1/4"	1500	ROLLER	6-705-TCI	6-705R-TCI	4-5/8"	7-1/8"
6"	2-1/4"	1700	ROLLER	6-706-TCI	6-706R-TCI	5-1/8"	8-1/8"
8"	2-1/4"	1800	ROLLER	6-708-TCI	6-708R-TCI	6-1/8"	10-1/4"
10"	2-1/4"	2200	ROLLER	6-710-TCI	6-710R-TCI	7-1/8"	12-1/4"
V-GROOVED - ECONOMICAL HANDLING OF HEAVY LOADS ON ANGLE TRACK							
6"	2-1/2"	1800	ROLLER	6-706-TCV	6-706R-TCV	5-1/8"	8-1/8"
8"	2-1/2"	2000	ROLLER	6-708-TCV	6-708R-TCV	6-1/8"	10-1/4"
URETHANE - FOR HEAVY LOADS AND ROUGH FLOOR CONDITIONS - ERGO*							
6"	2-1/4"	1500	ROLLER	6-706-TU	6-706R-TU	5-1/8"	8-1/8"
8"	2-1/2"	1800	ROLLER	6-708-TU	6-708R-TU	6-1/8"	10-1/4"

* Ergonomically designed for easy rolling.



6-908-TN



6-908B-TCI

FEATURES

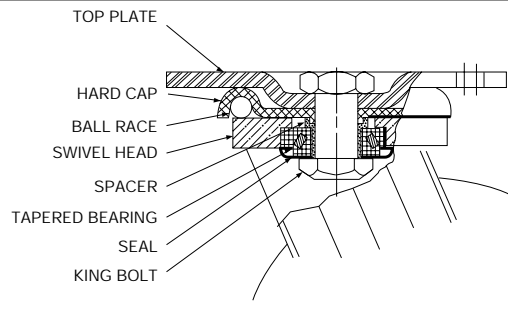

- 3/4" Axle
- 7/8" Grade 8 King bolt
- 4" Diameter upper raceway, 1/2" balls
- 5/8" Thick swivel head, precision machined and equipped with tapered roller bearings
- Ribbed legs for extra strength
- Grease fittings in swivel and wheel
- Bright zinc finish
- All swivel parts case hardened to Rockwell 62C

OPTIONS

- Brakes available. Add letter "B".
- Four Position Swivel locks. Add letter "F"
- Brakes and swivel locks cannot be combined on the same caster.

INSTALLATION

NO. 6 TOP PLATE

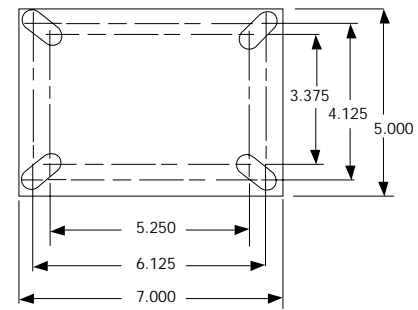

HOLES FOR 0.500 BOLTS

WHEEL DIAMETER	TREAD WIDTH	LOAD CAP./LBS	BEARING TYPE	SWIVEL MODEL	RIGID MODEL	SWIVEL RADIUS	OVERALL HEIGHT
SEMI-STEEL - CROWNED SEMI-STEEL CASTING							
6"	3"	3500	ROLLER	6-906-TCI	6-906R-TCI	5-1/4"	8-1/4"
6"	3"	3500	TAPERED	6-906-YCI	6-906R-YCI	5-1/4"	8-1/4"
8"	3"	3500	ROLLER	6-908-TCI	6-908R-TCI	6-1/4"	10-1/4"
8"	3"	3500	TAPERED	6-908-YCI	6-908R-YCI	6-1/4"	10-1/4"
10"	3"	3500	ROLLER	6-910-TCI	6-910R-TCI	7-1/4"	12-1/4"
10"	3"	3500	TAPERED	6-910-YCI	6-910R-YCI	7-1/4"	12-1/4"
12"	3"	3500	ROLLER	6-912-TCI	6-912R-TCI	8-1/4"	14-1/4"
12"	3"	3500	TAPERED	6-912-YCI	6-912R-YCI	8-1/4"	14-1/4"
URETHANE - FOR HEAVY LOADS AND ROUGH FLOOR CONDITIONS - ERGO*							
6"	3"	2500	ROLLER	6-906-TU	6-906R-TU	5-1/4"	8-1/4"
6"	3"	2500	TAPERED	6-906-YU	6-906R-YU	5-1/4"	8-1/4"
8"	3"	3000	ROLLER	6-908-TU	6-908R-TU	6-1/4"	10-1/4"
8"	3"	3000	TAPERED	6-908-YU	6-908R-YU	6-1/4"	10-1/4"
10"	3"	3500	ROLLER	6-910-TU	6-910R-TU	7-1/4"	12-1/4"
10"	3"	3500	TAPERED	6-910-YU	6-910R-YU	7-1/4"	12-1/4"
12"	3"	3500	ROLLER	6-912-TU	6-912R-TU	8-1/4"	14-1/4"
12"	3"	3500	TAPERED	6-912-YU	6-912R-YU	8-1/4"	14-1/4"
INDUSTRIAL WHEELS - HIGH QUALITY NATURAL RUBBER FOR EASE OF MOBILITY							
6"	3"	700	ROLLER	6-906-TN	6-906R-TN	5-1/4"	8-1/4"
8"	3"	900	ROLLER	6-908-TN	6-908R-TN	6-1/4"	10-1/4"
10"	3"	1100	ROLLER	6-910-TN	6-910R-TN	7-1/4"	12-1/4"
12"	3"	1200	ROLLER	6-912-TN	6-912R-TN	8-1/4"	14-1/4"

* Ergonomically designed for easy rolling.

5000 SERIES

CAPACITY : 2000 - 5000 LBS. PER CASTER



5-5008-TU



5-5008R-TU

FEATURES

- 1" Axle
- 1" King bolt
- Precision machined swivel head equipped with tapered bearings
- Ribbed legs for strength
- Grease fittings in swivel and wheel

OPTIONS

- Brakes available. Add letter "B".

INSTALLATION

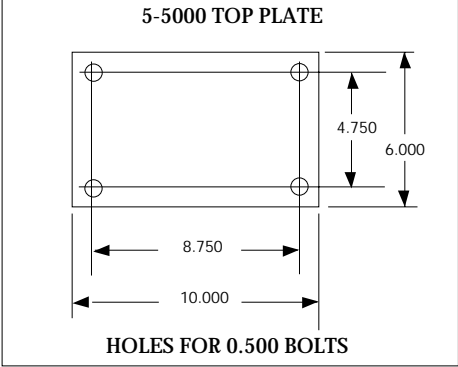

WHEEL DIAMETER	TREAD WIDTH	LOAD CAP./LBS	BEARING TYPE	SWIVEL MODEL	RIGID MODEL	SWIVEL RADIUS	OVERALL HEIGHT
SEMI-STEEL - CROWNED SEMI-STEEL CASTING							
6	3"	5000	ROLLER	5-5006-TCI	5-5006R-TCI	6-1/8"	8-5/8"
6	3"	5000	TAPERED	5-5006-YCI	5-5006R-YCI	6-1/8"	8-5/8"
8	3"	5000	ROLLER	5-5008-TCI	5-5008R-TCI	7-3/8"	10-5/8"
8	3"	5000	TAPERED	5-5008-YCI	5-5008R-YCI	7-3/8"	10-5/8"
10	3"	5000	ROLLER	5-5010-TCI	5-5010R-TCI	8-1/4"	12-5/8"
10	3"	5000	TAPERED	5-5010-YCI	5-5010R-YCI	8-1/4"	12-5/8"
12	3"	5000	ROLLER	5-5012-TCI	5-5012R-TCI	9-3/8"	14-3/4"
12	3"	5000	TAPERED	5-5012-YCI	5-5012R-YCI	9-3/8"	14-3/4"
V-GROOVED - ECONOMICAL HANDLING OF HEAVY LOADS ON ANGLE TRACK							
8	2-5/8"	2000	ROLLER	5-5008-TBCV	5-5008R-TBCV	7-3/8"	10-5/8"
URETHANE - FOR HEAVY LOADS AND ROUGH FLOOR CONDITIONS - ERGO*							
6	3"	2500	ROLLER	5-5006-TU	5-5006R-TU	6-1/8"	8-5/8"
6	3"	2500	TAPERED	5-5006-YU	5-5006R-YU	6-1/8"	8-5/8"
8	3"	3000	ROLLER	5-5008-TU	5-5008R-TU	7-3/8"	10-5/8"
8	3"	3000	TAPERED	5-5008-YU	5-5008R-YU	7-3/8"	10-5/8"
10	3"	3500	ROLLER	5-5010-TU	5-5010R-TU	8-1/4"	12-5/8"
10	3"	3500	TAPERED	5-5010-YU	5-5010R-YU	8-1/4"	12-5/8"
12	3"	4000	ROLLER	5-5012-TU	5-5012R-TU	9-3/8"	14-3/4"
12	3"	4000	TAPERED	5-5012-YU	5-5012R-YU	9-3/8"	14-3/4"

* Ergonomically designed for easy rolling.

5200 SERIES / TWIN WHEEL

CAPACITY: 1400 - 10000 LBS. PER CASTER



5-5210-TCI



5-5210R-TCI

FEATURES

- 1" Axle
- 1 - 1/4" King bolt
- Dual wheel construction for easier swiveling
- Precision machined swivel head equipped with tapered bearings
- Grease fittings in swivel and wheel

OPTIONS

- Brakes available. Add letter "B".
- Swivel locks available. Add letter "F".

INSTALLATION

5-5200 TOP PLATE

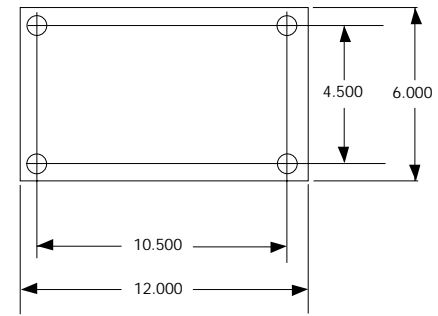

HOLES FOR 0.500 BOLTS

WHEEL DIAMETER	TREAD WIDTH	LOAD CAP./LBS	BEARING TYPE	SWIVEL MODEL	RIGID MODEL	SWIVEL RADIUS	OVERALL HEIGHT
SEMI-STEEL - CROWNED SEMI-STEEL CASTING							
6"	3"	10000	ROLLER	5-5206-TCI	5-5206R-TCI	5-7/8"	9-7/8"
6"	3"	10000	TAPERED	5-5206-YCI	5-5206R-YCI	5-7/8"	9-7/8"
8"	3"	10000	ROLLER	5-5208-TCI	5-5208R-TCI	6-3/4"	11-3/4"
8"	3"	10000	TAPERED	5-5208-YCI	5-5208R-YCI	6-3/4"	11-3/4"
10"	3"	10000	ROLLER	5-5210-TCI	5-5210R-TCI	7-5/8"	13-3/4"
10"	3"	10000	TAPERED	5-5210-YCI	5-5210R-YCI	7-5/8"	13-3/4"
12"	3"	10000	ROLLER	5-5212-TCI	5-5212R-TCI	8-5/8"	15-3/4"
12"	3"	10000	TAPERED	5-5212-YCI	5-5212R-YCI	8-5/8"	15-3/4"
URETHANE - FOR HEAVY LOADS AND ROUGH FLOOR CONDITIONS - ERGO*							
6"	3"	5000	ROLLER	5-5206-TU	5-5206R-TU	5-7/8"	9-7/8"
6"	3"	5000	TAPERED	5-5206-YU	5-5206R-YU	5-7/8"	9-7/8"
8"	3"	6000	ROLLER	5-5208-TU	5-5208R-TU	6-3/4"	11-3/4"
8"	3"	6000	TAPERED	5-5208-YU	5-5208R-YU	6-3/4"	11-3/4"
10"	3"	7000	ROLLER	5-5210-TU	5-5210R-TU	7-5/8"	13-3/4"
10"	3"	7000	TAPERED	5-5210-YU	5-5210R-YU	7-5/8"	13-3/4"
12"	3"	8000	ROLLER	5-5212-TU	5-5212R-TU	8-5/8"	15-3/4"
12"	3"	8000	TAPERED	5-5212-YU	5-5212R-YU	8-5/8"	15-3/4"
INDUSTRIAL WHEELS - HIGH QUALITY NATURAL RUBBER FOR EASE OF MOBILITY							
6"	3"	1400	ROLLER	5-5206-TN	5-5206R-TN	5-7/8"	9-7/8"
8"	3"	1800	ROLLER	5-5208-TN	5-5208R-TN	6-3/4"	11-3/4"
10"	3"	2200	ROLLER	5-5210-TN	5-5210R-TN	7-5/8"	13-3/4"
12"	3"	2400	ROLLER	5-5212-TN	5-5212R-TN	8-5/8"	15-3/4"

* Ergonomically designed for easy rolling.

PNEUMATIC CASTERS

CAPACITY: 300 - 2700 LBS. PER CASTER



6-310-TPN



6-3218-YPN



52-3318FP-YPN

FEATURES

- 300 Series
 - Manufactured with the same swivel construction as the 700 series
 - 4 Ply wheels equipped with roller bearings
 - Grease fittings in swivel and wheel for easy lubrication
- 31, 32, 3300 Series
 - Heavy duty swivel equipped with tapered roller bearings
 - King pin threaded, and welded to plate for extra strength
 - 4 Ply tires rated for 5 M.P.H.
 - Tapered roller bearings in wheels, supported by protective seals
 - Grease fittings in wheel and swivel

OPTIONS

- Available with swivel locks
- Wheels may be polyurethane filled to eliminate flats

INSTALLATIONS

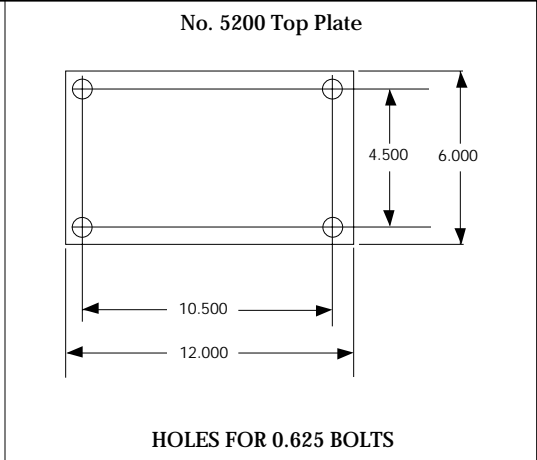
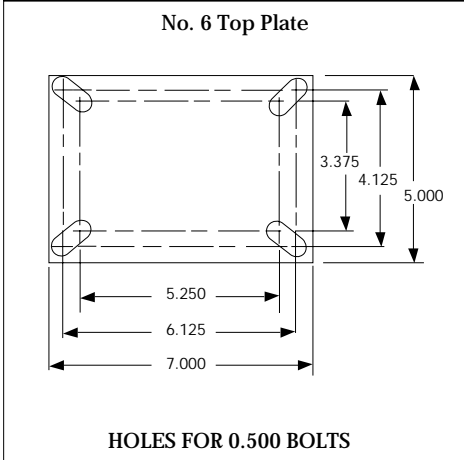

WHEEL DIAMETER	TREAD WIDTH	LOAD CAP./LBS	BEARING TYPE	SWIVEL MODEL	RIGID MODEL	SWIVEL RADIUS	OVERALL HEIGHT
8"	2-3/8"	300	ROLLER	6-308-TPN	6-308R-TPN	7-3/8"	11-3/4"
10"	3-5/8"	350	ROLLER	6-310-TPN	6-310R-TPN	8-1/4"	12-1/2"
16"	4-1/2"	750	TAPERED	6-3116-YPN	6-3116R-YPN	12-3/4"	20-1/2"
18"	5-3/4"	900	TAPERED	6-3118-YPN	6-3118R-YPN	13-3/4"	21-1/2"
16"	4-1/2"	1500	TAPERED	6-3216-YPN	6-3216R-YPN	14-1/4"	20-1/2"
18"	5-3/4"	1800	TAPERED	6-3218-YPN	6-3218R-YPN	15-1/4"	21-1/2"
18"	5-3/4"	2700	TAPERED	52-3318-YPN	52-3318R-YPN	16"	22"

V-GROOVE CASTERS

CAPACITY: 300 - 2000 LBS. PER CASTER

FEATURES

- High quality semi-steel wheels, machined to close tolerances
- Economical handling of heavy loads
- Floor protection
- Adaptability, (will roll on track or floor)
- Free rolling on sediment covered floors as the angle iron track is self cleaning

OPTIONS AND INSTALLATIONS

See proper series page of model selected for available options, and pages 15, 16 and 17 for available installations.



31-405-TCV



31-75R-TCV

WHEEL DIAMETER	TREAD WIDTH	LOAD CAP./LBS	BEARING TYPE	SWIVEL MODEL	RIGID MODEL	SWIVEL RADIUS	OVERALL HEIGHT
3"	1-1/4"	300	SLEEVE	16-63-CV	16-63R-CV	2-3/4"	4-5/16"
4"	1-3/8"	500	ROLLER	31-74-TCV	31-74R-TCV	3-1/2"	5-9/16"
4"	2"	800	ROLLER	31-404-TCV	31-404R-TCV	3-5/8"	5-5/8"
5"	1-1/2"	600	ROLLER	31-75-TCV	31-75R-TCV	4"	6-5/8"
5"	2"	1000	ROLLER	31-405-TCV	31-405R-TCV	4-1/4"	6-11/16"
6"	2-1/2"	1500	ROLLER	8-806-TCV	8-806R-TCV	5-1/8"	8-1/8"
8"	2-1/2"	1800	ROLLER	8-808-TCV	8-808R-TCV	6-1/8"	10-1/4"
8"	2-5/8"	2000	ROLLER	5008-TBCV	5008R-TBCV	7-3/8"	10-5/8"

V-GROOVE

WHEEL DIMENSIONS

WHEEL DIAMETER	TREAD WIDTH	LOAD CAP./LBS	WHEEL MODEL	BEARING TYPE	BORE SIZE	HUB LENGTH	USED IN CASTER SERIES
3"	1-1/4"	300	W-63-CV	SLEEVE	3/8"	1-1/2"	60
4"	1-3/8"	500	W-74-TCV	ROLLER	3/8"	1-3/4"	70
4"	2"	800	W-404-TCV	ROLLER	1/2"	2-5/16"	400
5"	1-1/2"	600	W-75-TCV	ROLLER	3/8"	1-3/4"	70
5"	2"	1000	W-405-TCV	ROLLER	1/2"	2-5/16"	400
6"	2-1/2"	1500	W-806-TCV	ROLLER	3/4"	2-3/4"	700/800
8"	2-1/2"	1500	W-808-TCV	ROLLER	3/4"	2-3/4"	700/800
8"	2-5/8"	2000	W-5008-TCV	ROLLER	3/4"	3-1/4"	900/5000

WHEEL DRAWINGS

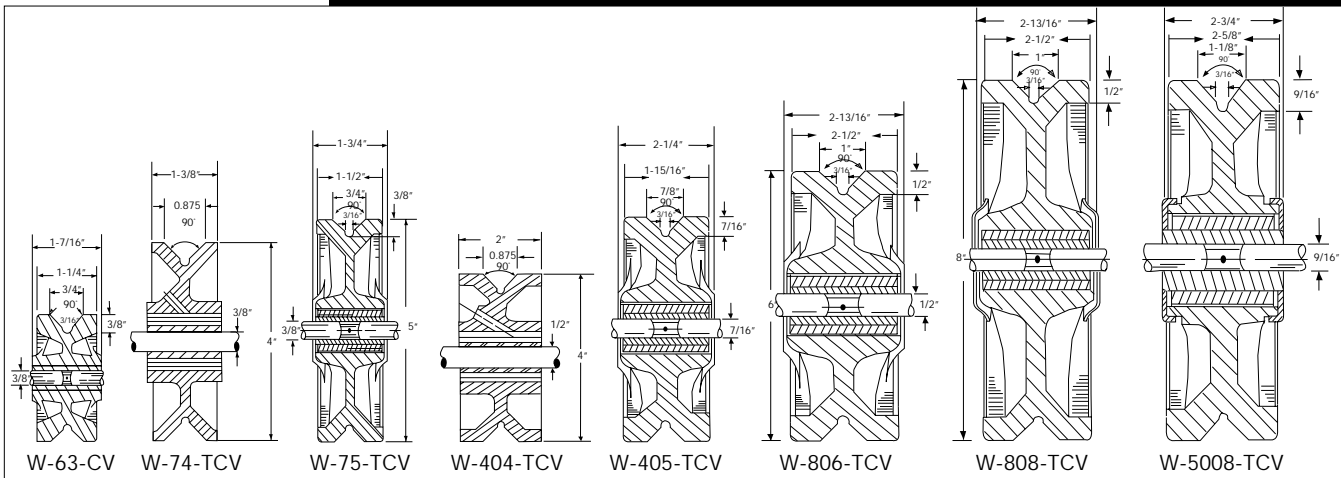

Tel • 1-416-255-8563

Fax • 1-416-251-6117



SPRING LOADED CASTERS

31-SL 400 SERIES



31-SL404-PSE

SPRING LOADED CASTERS

FEATURES

- Oil impregnated permanently lubricated sintered bearings for all moving parts
- Sealed precision ball bearings in the wheel permanently lubricated for long life and low rolling resistance
- Sealed swivel assembly with grease fitting for ease of access
- Load rating 1000 pounds at maximum spring deflection
- Various Mounting plates available

Available in 3", 4", 5", 6" , and 8" models

INSTALLATIONS

NO. 31 TOP PLATE
(STANDARD ON 400 SERIES)

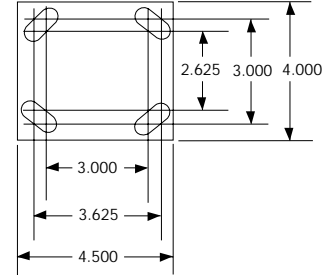

HOLES FOR 0.375 BOLTS

WHEEL DIAMETER	TREAD WIDTH	LOAD CAP./LBS	BEARING TYPE	MODEL NUMBER	SWIVEL RADIUS	OVERALL HEIGHT NO LOAD	OVERALL HEIGHT MAX. LOAD
SOLID ELASTOMER - VERY LOW STARTING AND ROLLING RESISTANCE - ERGO*							
3"	2"	900	PRECISION BALL	31-SL403-PSE	3.50"	7.00"	6.00"
4"	2"	900	PRECISION BALL	31-SL404-PSE	4.00"	7.50"	6.50"
5"	2"	1000	PRECISION BALL	31-SL405-PSE	4.85"	9.00"	8.00"
6"	2"	1000	PRECISION BALL	31-SL406-PSE	5.30"	9.50"	8.50"
8"	2"	800	PRECISION BALL	31-SL408-PSE	7.30"	11.50"	10.00"
NEOPRENE - NON MARKING AND NON STAINING - USED ON ANY FLOOR SURFACE - ERGO*							
4"	2"	450	PRECISION BALL	31-SL404-PD	4.00"	7.50"	6.50"
5"	2"	500	PRECISION BALL	31-SL405-PD	4.85"	9.00"	8.00"
6"	2"	550	PRECISION BALL	31-SL406-PD	5.30"	9.50"	8.50"
8"	2"	550	PRECISION BALL	31-SL408-PD	7.30"	11.50"	10.00"

6-SL 900 SERIES

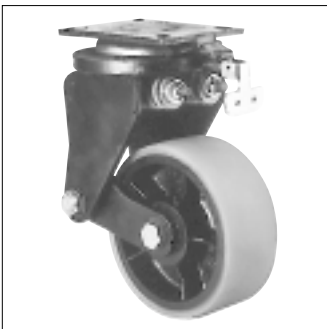

6-SL908-YU

SPRING LOADED CASTERS

FEATURES

- Oil impregnated permanently lubricated sintered bearings for all moving parts
- Tapered bearings in swivel
- Load rating to 2500 lbs
- Available in 5", 8", and 10" models
- Can be manufactured in additional sizes as required

INSTALLATIONS

NO. 6 TOP PLATE

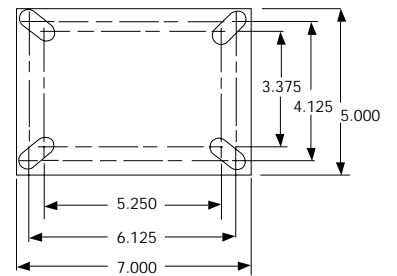

HOLES FOR 0.500 BOLTS

WHEEL DIAMETER	TREAD WIDTH	LOAD CAP./LBS	BEARING TYPE	MODEL NUMBER	SWIVEL RADIUS	OVERALL HEIGHT NO LOAD	OVERALL HEIGHT MAX. LOAD
5"	2-1/2"	1000	PRECISION BALL	6-SL905-PSE	4.50"	10.00"	7.25"
8"	3"	2500	TAPERED	6-SL908-YU	6.45"	13.00"	12.00"
10"	3"	2500	TAPERED	6-SL910-YU	8.60"	15.00"	14.00"

* Ergonomically designed for easy rolling.

SPRING LOADED CASTERS

SL 8510-YU

SPRING LOADED CASTER

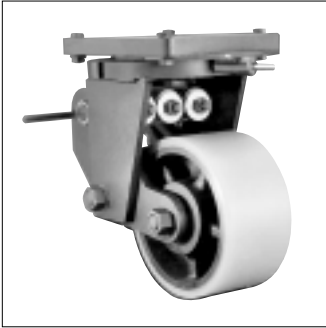

SL-8510-YU

FEATURES

- Oil impregnated bearings in all pivoting points
- Grease fitting in swivel and wheel
- Sealed bearings in wheel
- Tapered bearings in swivel head and wheel
- Four position swivel locks and brakes available

INSTALLATION

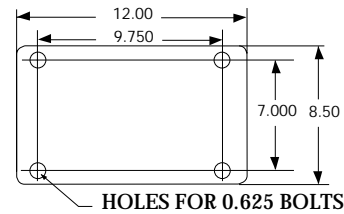

WHEEL DIAMETER	TREAD WIDTH	LOAD CAP./LBS	BEARING TYPE	MODEL NUMBER	SWIVEL RADIUS	OVERALL HEIGHT NO LOAD	OVERALL HEIGHT MAX. LOAD
10"	5"	10,000	TAPERED	SL8510-YU	9.40"	15.625"	14.50"

TWIN WHEEL

SPRING LOADED CASTERS

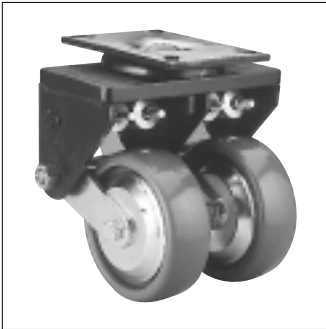

6-TSL2406-PSE

FEATURES

- Twin wheels reduced resistance to swiveling
- Twin wheels spread load over a wider area
- Twin wheels offer higher load carrying capacity
- Available with swivel locks

INSTALLATION

No. 6 and 5200 Top plates
See page 16 for dimensions

WHEEL DIAMETER	TREAD WIDTH	LOAD CAP./LBS	BEARING TYPE	MODEL NUMBER	SWIVEL RADIUS	OVERALL HEIGHT NO LOAD	OVERALL HEIGHT MAX. LOAD
6"	2"	2200	PRECISION BALL	6-TSL2406-PSE	6.30"	9.45"	8.45"
8"	3"	6000	TAPERED	Q-TSL5208-YU	9.60"	14.75"	12.25"

GATE SPRING LOADED CASTERS



QSL-22-XD



QSL-32-XD

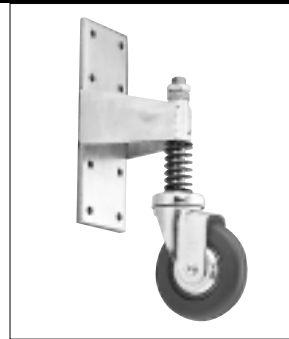

QSL-75-XD



QSL-405-TD

WHEEL DIAMETER	CASTER MODEL NO.	OVERALL HEIGHT NO LOAD	OVERALL HEIGHT MAX. LOAD	SWIVEL OFFSET C/W BRACKET	LOAD CAPACITY
2"	QSL-22-XD	7.375"	6.375"	1.750"	75 lbs.
2"	QSL-32-XD	8.500"	7.625"	3.500"	200 lbs.
5"	QSL-75-XD	13.250"	12.000"	5.375"	300 lbs.
5"	QSL-405-TD	13.250"	12.000"	5.375"	400 lbs.

LIFT TRUCK APPLICATIONS

FEATURES

Darcor offers a unique line of Spring Loaded Casters for lift trucks. Ergonomically designed, these easy to maneuver casters offer the utmost in superior performance. Darcor "SE" Solid Elastomer Wheels are chemical resistant and show minimal wear or heat buildup in extended use. Spring Loaded Casters equipped with SE wheels feature precision sealed ball bearings and require little maintenance. Darcor also supplies "high quality" Polyurethane wheels with tapered bearings for heavier loads and varying speed conditions.



LT1

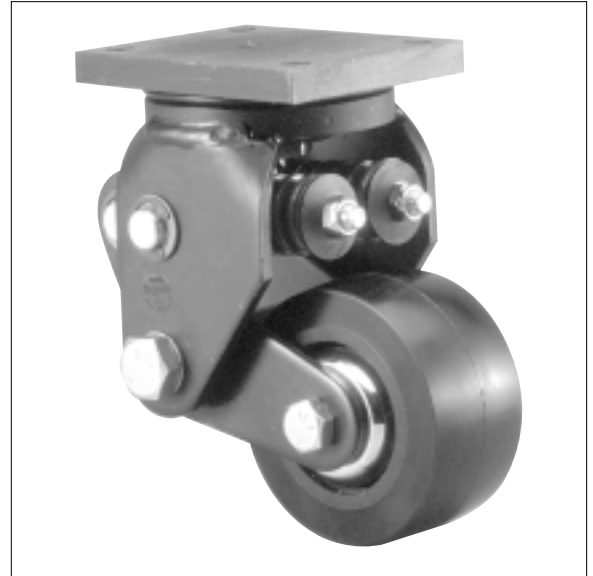

LT2



LT3



LT4

WHEEL DIAMETER	TREAD WIDTH	LOAD CAP./LBS	BEARING TYPE	MODEL NUMBER	SWIVEL RADIUS	OVERALL HEIGHT NO LOAD	OVERALL HEIGHT MAX. LOAD
4"	2"	800	PRECISION BALL	LT2	4.125	7.375"	6.375"
4"	2-1/2"	1200	PRECISION BALL	LT1	5	8.66"	7.66"
4"	2-1/2"	1000	PRECISION BALL	LT3	4	7.56"	6.56"
6"	2-1/2"	1000	PRECISION BALL	LT4	5	11.4"	10.4"

- Pre-loading and custom spring rates/capacity available as special order.

Internet • www.darcor.com

E-mail • casters@darcor.com

The following are just a few of our special application casters. They have been designed to meet specific requirements of customers by our engineering department. These applications are found in many different areas of industry so we feel it is important to show these casters in their own section of our catalogue. We hope they will offer you a solution to your own unusual or special application problems. We encourage you to call us if you don't find the caster you require in our catalogue.



8216-YU

16,800 lbs. capacity caster with twin 16" x 5" polyurethane wheels. Extra heavy assembly designed to withstand extreme thrust on king pin. Presently being used in the mining industry OH 21-3/4".



9K

20,000 lbs. capacity steel wheel caster with an overall height of just 1/2". This caster was designed to move a large heavy load in a confined area where overall height was restricted. Available in swivel and rigid models, it can be supplied in larger sizes as well.



TURTLE

"Turtle" Caster designed for load ratings from 600 lbs. to 2,500 lbs. Equipped with 3 swivel casters mounted to a swivel head. Good for low heights and heavy loads. Reduced swivel effort gives a smooth gliding action while protecting floor surfaces. Excellent choice for applications such as studio, theatre and stage equipment.



31-224-XD

300 lbs. twin wheel caster available with either 3" or 4" diameter wheels and can be supplied with any fittings applicable to the 70 series. The twin wheels offer easier swiveling and are ideal for equipment going on and off elevators where single wheel casters tend to get caught in the entrance.



31-274-PSE

Twin wheel caster, equipped with solid elastomer sealed precision ball bearing wheels. Twin wheels maintain a low profile while providing easy pivoting action. Good for heavy loads, offering ease of movement over floor gaps and joints. Excellent for continuous use operations such as tow lines, and Automatic Guided Vehicles.



8-2404-PSE

CARTWASHABLE™ CASTERS

CAPACITY: 225-1000 LBS. PER CASTER



31-CW76-XD



31-CW76B-XD



31-CW76R-XD

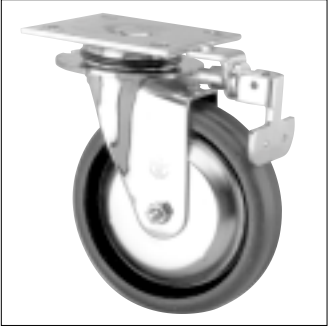

31-CW76F-XSR

FEATURES

After years of actual experiments and hundreds of tests, we have developed a line of casters to reduce rusting under wet conditions. Hospital laundries and dietary departments, plus hotel and motel areas concerned with sanitary operations will find the cartwashable design reduces maintenance and provides extra life both to the casters and equipment. The medium and heavy duty models are ideally suited to the sanitary conditions dictated by experimental and pharmaceutical laboratories as well as firms connected to the meat packing and food industries.

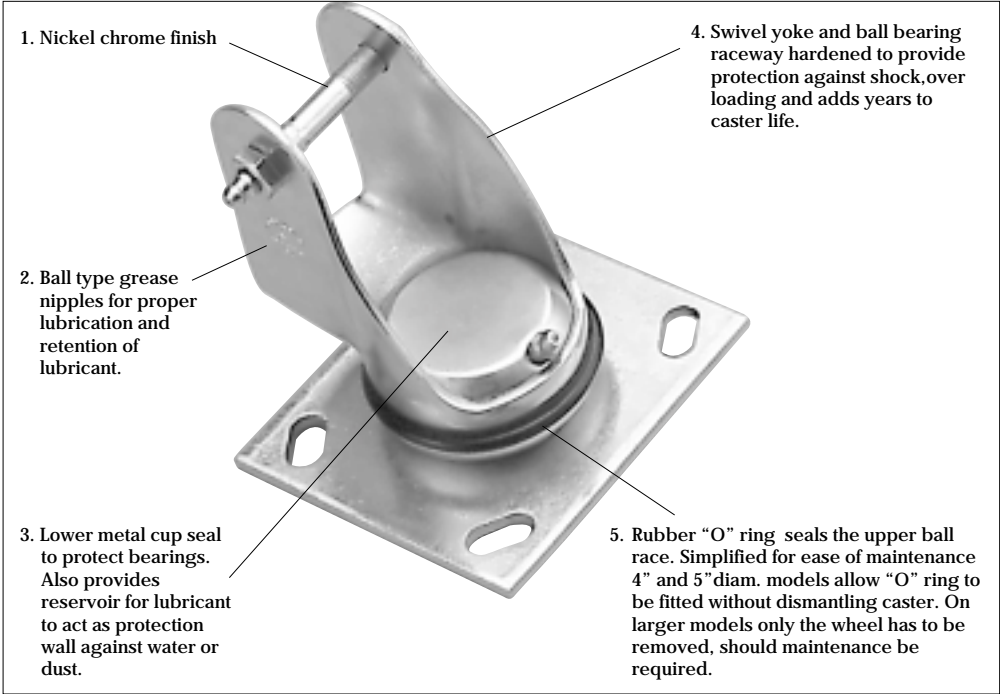

INSTALLATIONS

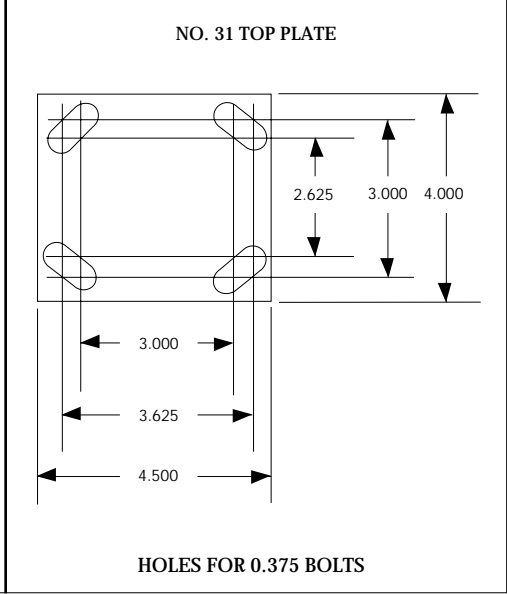
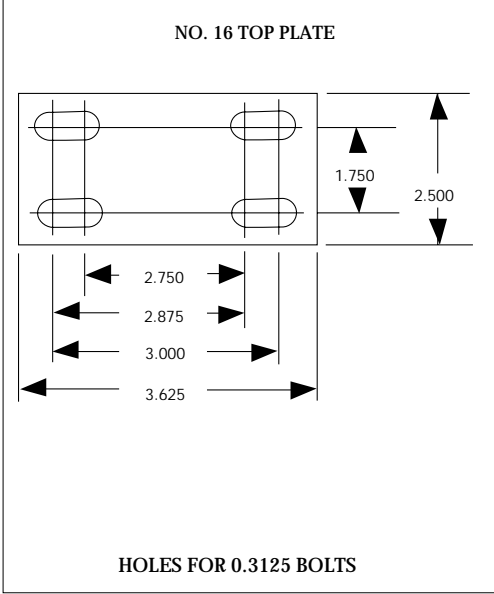

OPTIONAL STEMS AND PLATES AVAILABLE UPON REQUEST. SEE PAGES 14, 15, 16.

CARTWASHABLE™ IS A REGISTERED TRADEMARK OF DARCOR CASTERS.

CARTWASHABLE™

CASTERS

WHEEL DIA.	TREAD WIDTH	LOAD CAP./LBS	BEARING TYPE	SWIVEL MODEL	RIGID MODEL	SWIVEL RADIUS	OVERALL HEIGHT
NEOPRENE - NON MARKING AND NON STAINING - USE ON ANY FLOOR SURFACE							
4"	1-3/8"	225	BALL	16-CW64-XD	16-CW64R-XD	3-1/4"	5-3/8"
4"	1-3/8"	250	BALL	31-CW74-XD	31-CW74R-XD	3-1/2"	5-9/16"
5"	1-3/8"	250	BALL	16-CW65-XD	16-CW65R-XD	4"	6-3/8"
5"	1-3/8"	275	BALL	31-CW75-XD	31-CW75R-XD	4"	6-5/8"
5"	2"	450	ROLLER	31-CW405-TD	31-CW405R-TD	4-1/4"	6-11/16"
5"	2"	550	PRECISION BALL	31-CW405-PD	31-CW405R-PD	4-1/4"	6-11/16"
6"	1-5/8"	300	BALL	31-CW76-XD	31-CW76R-XD	4-7/8"	7-9/16"
6"	2"	500	ROLLER	31-CW406-TD	31-CW406R-TD	4-5/8"	7-11/16"
6"	2"	600	PRECISION BALL	31-CW406-PD	31-CW406R-PD	4-5/8"	7-11/16"
8"	2"	500	ROLLER	31-CW408-TD	31-CW408R-TD	5-3/4"	9-3/4"
8"	2"	600	PRECISION BALL	31-CW408-PD	31-CW408R-PD	5-3/4"	9-3/4"
SUPER ROLL NEOPRENE - SOFT LOW PROFILE TREAD FOR EASY STARTING AND ROLLING							
4"	1-3/8"	250	BALL	16-CW64-XSR	16-CW64R-XSR	3-1/4"	5-3/8"
4"	1-3/8"	300	BALL	31-CW74-XSR	31-CW74R-XSR	3-1/2"	5-9/16"
5"	1-3/8"	275	BALL	16-CW65-XSR	16-CW65R-XSR	4"	6-3/8"
5"	1-3/8"	350	BALL	31-CW75-XSR	31-CW75R-XSR	4"	6-5/8"
6"	1-1/2"	400	BALL	31-CW76-XSR	31-CW76R-XSR	4-7/8"	7-9/16"
SOLID ELASTOMER - VERY LOW STARTING AND ROLLING RESISTANCE							
4"	1-3/8"	600	PRECISION BALL	31-CW74-PSE	31-CW74R-PSE	3-1/2"	5-9/16"
5"	1-3/8"	600	PRECISION BALL	31-CW75-PSE	31-CW75R-PSE	4"	6-5/8"
5"	2"	1000	PRECISION BALL	31-CW405-PSE	31-CW405R-PSE	4-1/4"	6-11/16"
6"	1-3/8"	600	PRECISION BALL	31-CW76-PSE	31-CW76R-PSE	4-7/8"	7-9/16"
6"	2"	1000	PRECISION BALL	31-CW406-PSE	31-CW406R-PSE	4-5/8"	7-11/16"
8"	2"	1000	PRECISION BALL	31-CW408-PSE	31-CW408R-PSE	5-3/4"	9-3/4"

CARTWASHABLE™

WHEELS

WHEEL DIA.	TREAD WIDTH	LOAD CAP./LBS	BALL BEARING	ROLLER BEARING	PRECISION BALL BEARING SEALED	BORE SIZE	HUB LENGTH	SERIES USED IN
NEOPRENE WHEELS - NON MARKING AND NON STAINING - USED ON ANY FLOOR SURFACE - ERGO*								
4"	1-3/8"	225	W-CW64-XD			3/8"	1-1/2"	60
4"	1-3/8"	250	W-CW74-XD			3/8"	1-3/4"	70
5"	1-3/8"	250	W-CW65-XD			3/8"	1-1/2"	60
5"	1-3/8"	275	W-CW75-XD			3/8"	1-3/4"	70
5"	2"	450/550		W-CW405-TD	W-CW405-PD	1/2"	2-3/8"	400
6"	1-1/2"	300	W-CW76XD			3/8"	1-3/4"	70
6"	2"	500/600		W-CW406-TD	W-CW406-PD	1/2"	2-3/8"	400
8"	2"	500/600		W-CW408-TD	W-CW408-PD	1/2"	2-3/8"	400
SUPER ROLL NEOPRENE - SOFT LOW PROFILE TREAD FOR EASY STARTING AND ROLLING								
4"	1-3/8"	250	W-CW64-XSR			3/8"	1-1/2"	60
4"	1-3/8"	300	W-CW74-XSR			3/8"	1-3/4"	70
5"	1-3/8"	275	W-CW65-XSR			3/8"	1-1/2"	60
5"	1-3/8"	350	W-CW75-XSR			3/8"	1-3/4"	70
6"	1-1/2"	400	W-CW76-XSR			3/8"	1-3/4"	70
SOLID ELASTOMER WHEELS - VERY LOW STARTING AND ROLLING RESISTANCE - ERGO*								
4"	1-3/8"	600			W-CW74-PSE	3/8"	1-3/4"	70
5"	1-3/8"	600			W-CW75-PSE	3/8"	1-3/4"	70
5"	2"	1000			W-CW405-PSE	1/2"	2-3/8"	400
6"	1-3/8"	600			W-CW76-PSE	3/8"	1-3/4"	70
6"	2"	1000			W-CW406-PSE	1/2"	2-3/8"	400
8"	2"	1000			W-CW408-PSE	1/2"	2-3/8"	400

MEDICAL APPLICATIONS

Darcor manufactures a complete line of ergonomically designed casters for medical and diagnostic equipment such as portable x-ray machines, MRI's and ultrasound machines. Darcor's twin wheel casters – featuring directional locks, brakes and central locking systems – are available with either LE or Neoprene wheels, which are quiet, non-marking and shock absorbent. Darcor is proud to manufacture a complete line of products that exceed current medical industry standards.



M6 SERIES

The Darcor M6 incorporates an advanced caster design and central locking mechanism that makes it an excellent choice for transporting the most sensitive diagnostic equipment. It can be custom-configured to meet the customer's precise specifications.



M5 SERIES

The robust, twin-wheel design of the M5 caster makes it ideal for applications, such as bariatric beds, where strength and maneuverability are critical. Equipped with shock-dampening wheels to cushion its load, the M5 is widely used in health-care facilities around the world.

SERIES	INSTALLATION	WHEEL DIA.	TREAD WIDTH	LOAD CAP./LBS	BRG TYPE SWIVEL/WHEEL	BRAKE MODEL	SWIVEL MODEL	SW. RAD	O.A.H.
M5	TOP PLATE	5"	1"	300	PRECISION/BALL	T-CLM5-XD	T-M5-XD	4-5/8"	6-7/8"
	STEM	5"	1"	300	PRECISION/BALL	S-CLM5-XD	S-M5-XD	4-5/8"	5-7/8"
M6	TOP PLATE	6"	7/10"	250	PRECISION/PRECISION	T-CLM6-PD	T-M6-PD	5-3/8"	8"
	STEM	6"	7/10"	250	PRECISION/PRECISION	S-CLM6-PD	S-M6-PD	5-3/8"	7"

- Mounting Option: Stem Diameter 1.1" (28 mm) Available as CL (Industry STD)
- Wheel Option: Neoprene (LE as special order)
- Finish: Off White on M5 models
Grey on M6 models

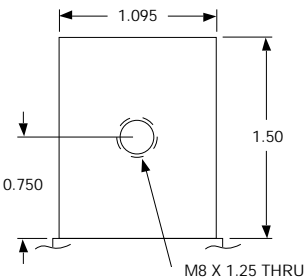

SWIVEL STEM

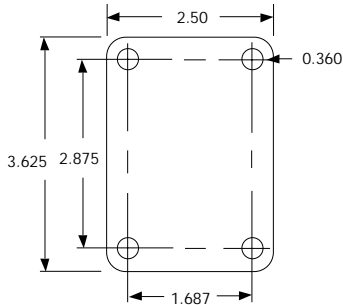

TOP PLATE

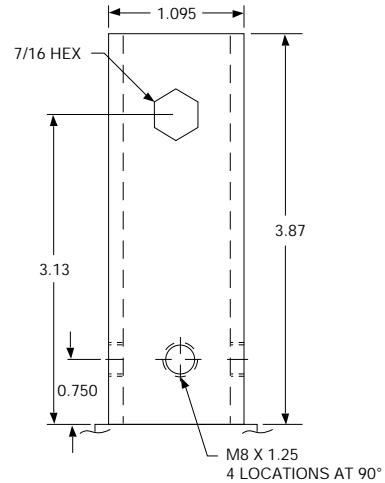

CENTRAL LOCK STEM (BRAKE MODEL)

HOSPITAL BED CASTER

LOCKS SWIVEL AND WHEEL

FEATURES

Our brake and swivel locking bed caster is the first North American design of this type. Designed with a cam action locking mechanism, the lever easily engages and disengages with the touch of a toe. As well as offering easy access, the lever design keeps it within the swivel radius of the caster, eliminating any interference. The assembly is available with nickel chrome finish (BC5) or zinc finish (BC45) and equipped with our non-marking Super Roll neoprene wheel complete with ball bearings.



OU-BC65B-XSR



OU-BC5-XSR



OU125-BC5B2-XSR

KEYWAY SOCKETS AND

STEM - Prevents stem from turning inside socket. For use with hospital bed total lock brakes.

- CSK 125 - Fits inside 1-1/4" 14 Gauge square tubing
- CSK 150 - Fits inside 1-1/2" 18 Gauge square tubing
- CSK 158 - Fits inside 1-5/8" 16 Gauge round tubing

ADAPTER AND STEM LOCK SOCKET - Prevents stem from turning. For use with hospital bed total lock brakes.

- OU 125 - Fits over 1-1/4" OD square tubing
- OU 150 - Fits over 1-1/2" OD square tubing

INSTALLATIONS

KEYWAY SOCKET AND STEM

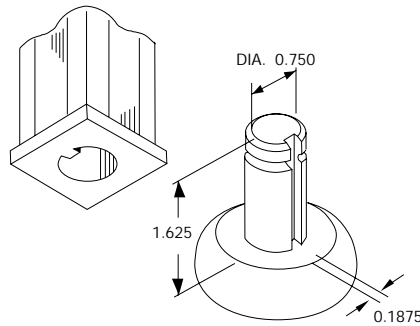

ADAPTER AND STEM LOCK SOCKET

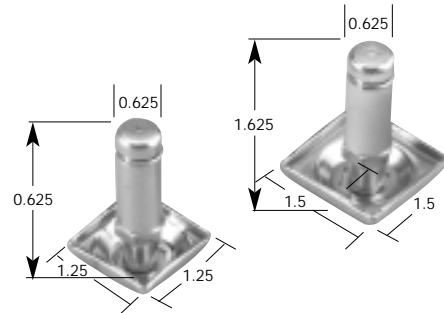

WHEEL DIAMETER	TREAD WIDTH	LOAD CAP./LBS	BEARING TYPE	SWIVEL MODEL	BRAKE MODEL	SWIVEL RADIUS	OVERALL HEIGHT
NEOPRENE SUPER ROLL - NON MARKING AND NON STAINING - USED ON ANY FLOOR SURFACE - ERGO*							
4"	1-3/8"	275	BALL	OU-BC64-XSR	OU-BC64B-XSR*	3-1/4"	5-3/8"
5"	1-3/8"	325	BALL	OU-BC65-XSR	OU-BC65B-XSR*	4"	6-3/8"
NEOPRENE SUPER ROLL - NON MARKING AND NON STAINING - USED ON ANY FLOOR SURFACE - ERGO*							
4"	1-3/8"	275	BALL	OU-BC4-XSR	OU-BC4B-XSR*	3-1/4"	5-3/8"
5"	1-3/8"	325	BALL	OU-BC5-XSR	OU-BC5B-XSR*	4"	6-3/8"

- B2 brake casters available on BC64 and BC65 casters with additional charge.
- All bed casters shown with OU 5/8" x 1-5/8" grip ring stem, optional stems and sockets as shown. Also available with all 60 series stems and top plates see pages 14,15 and 16.
- * Stems should be secured on brake casters to prevent turning when swivel lock is engaged.
- * Ergonomically designed for easy rolling.

HOSPITAL CASTERS

Darcor has been supplying casters to hospitals for over 60 years and has become recognized as the leading authority for solving replacement caster problems. We have been involved in both new and existing applications for major hospitals in cities all over North America.

We recommend our specially formulated neoprene wheel for most applications found in hospitals. It is very quiet, extremely easy to roll over all surfaces including carpet and quarry tile, resists chemicals and cleaning compounds common to the hospital environment, and is **GUARANTEED NON MARKING AND NON STAINING**

For heavier loads, the **SOLID ELASTOMER** wheel is an ideal solution. On the following pages (45, 46, 47), we will identify some of the more common applications, and the casters we recommend for them. As well, we elaborated (pages 41, 42, 44) on bed casters, and wash down applications with casters specifically designed for these and other problem areas in hospitals.



OC-E2-XD

- Bedside and Overbed Tables
- O.R. Equipment
- I.V. Stands
- Office Chairs (Tile)



OC-53-XD

- I.V. Stands
- Nursery cribs
- Incubators
- Office Chairs (Carpet)



I.V. STAND FITTED WITH DARCOR NEOPRENE 53-XD

HOSPITAL CASTERS



12-24B-XD



12-24-XD

- Medicine Carts
- Commode Chairs (With Stem Mount)



MEDICINE CART

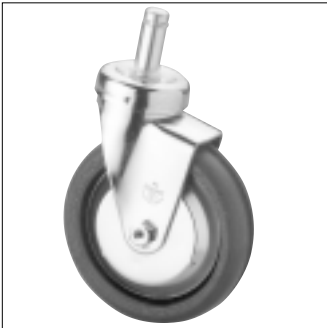

OU-BC5-XSR



OU125-BC5B2-XSR

- Hospital Bed Casters available in 4" and 5" models with combination swivel lock and brake. See page 44 for complete description.



HOSPITAL BED



31-76-XD

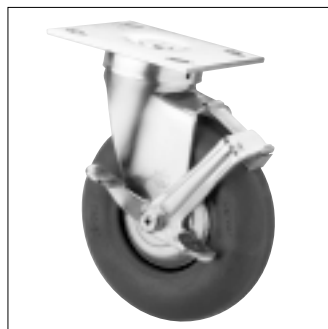

31-76B-XD

- Portable Ultrasound Machines
- Crash Carts
- Kitchen Equipment



DIAGNOSTIC EQUIPMENT

HOSPITAL CASTERS



FOOD CART

- Supply Carts
- Linen Trucks
- Kitchen Tray Trucks
- Portable X-Ray Equipment



31-76S-XSR



31-408-TD



SUPPLY CART

- Heated Food Trucks
- Laundry Trucks
- Housekeeping Carts
- Maintenance Carts



16-65B-XSR



31-76-XD

NEOPRENE WHEELS - SUPER ROLL NEOPRENE WHEELS

TREAD SYMBOL "D"

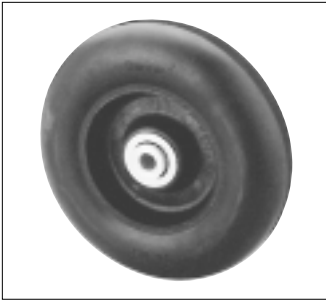

W-76-XD

NEOPRENE
TREAD SYMBOL "D"
DUROMETER - SHORE 62 "A"

Superior for all floor surfaces and ergonomically designed for excellent mobility and resistance to wear. These quiet and easy rolling wheels are very shock absorbing, non-marking and will reject floor debris, roll over screws, metal or glass fragments, resin pellets and are non-staining. Darcor "VQ" very quiet ball bearings are standard in the 20 through 70 series. Precision ball bearings "P" are recommended in the 400 series. Sizes available 2" to 8".

TREAD SYMBOL "SR"

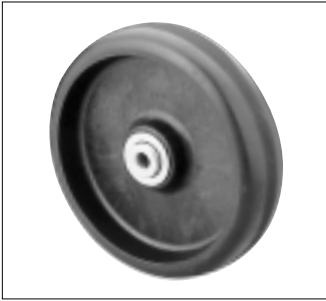

W-76-XSR

NEOPRENE
TREAD SYMBOL "SR"
DUROMETER - SHORE 62 "A"

The "SR" wheels offer the same high quality as "D" wheels but with a low profile tread for easier swiveling and very low rolling resistance.

- Shore Hardness 59-63 "A" Scale
- Non marking and non staining
- Temperature ranges 300° F for 20 minutes, 175° F for 1 hour
- Highly resistant to wax, oils, greases, cleaning compounds, weather and ozone.
- Can be used on all floor surfaces
- Does not flat spot when sitting for long periods under load

* All Darcor "D" and "SR" wheels are mold-on wheels with a neoprene tread thermally bonded to a glass fibre reinforced nylon core for exceptional strength, impact resistance and outstanding rollability.

NEOPRENE WHEEL CHEMICAL RESISTANCE GUIDE

This table lists a broad range of fluids and chemicals which are considered compatible with our Neoprene wheel. Ratings are at 72°F unless specified otherwise. Concentrations of aqueous solutions are saturated, except where noted. Note especially that this data is based on laboratory tests and may vary in practice. Field testing is suggested to confirm these recommendations. Only those chemicals that have little or no effect on the Neoprene wheel are listed here. Other fluids may have a very minor or major effect. For information on the compatibility of other fluids contact engineering.

Acetic acid, 20%	Castor oil	Hydrochloric acid, 20%	Potassium hydroxide, dilute solutions
Acetic acid, 30%	Chlorine gas, dry	Hydrochloric acid, 37%	Sea water
Acetic anhydride	Chloroacetic acid	Hydrocyanic acid	Silicone grease
Acetone	Citric acid solutions	Hydrofluoric acid, up to 75%	Soap solutions
Acetylene	Copper chloride solutions	Hydrofluoric acid, anhydrous	Sodium chloride solutions
Aluminium chloride solutions	Copper sulfate solutions	Hydrogen	Sodium dichromate, 20%
Aluminium sulfate solutions	Cottonseed oil	Hydrogen peroxide, 90%	Sodium hydroxide, up to 23%
Ammonia, anhydrous	DOWTHERM A	Hydrogen sulfide	Sodium hydroxide, 46½%
Ammonium chloride solutions	Ethyl alcohol	Isooctane	Sodium hypochlorite, up to 20%
Ammonium hydroxide solutions	Ethylene glycol	Isopropyl alcohol	Sodium peroxide solutions
Ammonium sulfate solutions	Ferric chloride solutions	Lactic acid	Soybean oil
Amyl alcohol	Fluosilicic acid	Linseed oil	Stannic chloride
ASTM oil #1	Formaldehyde, 40%	Lubricating oils	Stannous chloride, 15%
ASTM oil #3	Formic acid	Magnesium chloride solutions	Steam
ASTM reference fuel A	FREON* -11	Magnesium hydroxide solutions	Stearic acid
Asphalt	FREON-11	Mercuric chloride solutions	Sulfur, molten
Barium hydroxide solutions	FREON-12	Mercury	Sulfur dioxide, gas
Beer	FREON-22	Methyl alcohol	Sulfur dioxide, liquid
Borax solutions	FREON-22 (130°F)	Mineral oil	Sulfuric acid, up to 60%
Boric acid solutions	FREON-113	Nitric acid, 10%	Tannic acid, 10%
Butane	FREON-113 (130°F)	Oleic acid	Tartaric acid
Butyraldehyde	FREON-114	Palmitic acid	Triethanolamine
Calcium bisulfite solutions	FREON-114 (130°F)	Phosphoric acid, 20%	Trisodium phosphate solutions
Calcium chloride solutions	Furfural	Phosphoric acid, 60%	Tung oil
Calcium hydroxide solutions	Gasoline	Phosphoric acid, 70%	Water
Calcium hypochlorite, up to 20%	Glue	Phosphoric acid, 85%	Zinc chloride solutions
Carbon dioxide	Glycerin	Pitric acid	
Carbon monoxide	n-Hexane	Potassium dichromate solutions	

WHEEL DIAMETER	TREAD WIDTH	LOAD CAP./LBS	BALL BEARING	ROLLER BEARING	PRECISION SEALED BALL BEARING	BORE SIZE	HUB LENGTH	USED IN CASTER SERIES
NEOPRENE WHEELS								
2"	1"	75	W-22-XD			5/16"	1-1/8"	20 ETERNITY 2
2"	1"	150	W-32-XD			5/16"	1-1/8"	30
3"	1"	75	W-53-XD			5/16"	1-1/8"	CARPET MASTER
3"	1"	75	W-23-XD			5/16"	1-1/8"	20
3"	1-3/8"	200	W-63-XD			3/8"	1-1/2"	60
3"	1-3/8"	225	W-73-XD			3/8"	1-3/4"	70
3-1/2"	1-3/8"	200	W-63.5-XD			3/8"	1-1/2"	60
4"	1"	75	W-24-XD			5/16"	1-1/8"	20
4"	1-3/8"	225	W-64-XD			3/8"	1-1/2"	60
4"	1-3/8"	250	W-74-XD			3/8"	1-3/4"	70
4"	2"	400/500		W-404-TD	W-404-PD	1/2"	2-5/16"	400
5"	1"	75	W-25-XD			5/16"	1-1/8"	20
5"	1-3/8"	250	W-65-XD			3/8"	1-1/2"	60
5"	1-3/8"	275	W-75-XD			3/8"	1-3/4"	70
5"	2"	450/550		W-405-TD	W-405-PD	1/2"	2-5/16"	400
6"	1-5/8"	300	W-76-XD			3/8"	1-3/4"	70
6"	2"	500/600		W-406-TD	W-406-PD	1/2"	2-5/16"	400
8"	2"	500/600		W-408-TD	W-408-PD	1/2"	2-5/16"	400
SUPER ROLL NEOPRENE WHEELS								
2-1/2"	1"	75	W-22.5-XSR			5/16"	1-1/8"	20
2-1/2"	1"	150	W-32.5-XSR			5/16"	1-1/8"	30
2-1/2"	1-3/8"	175	W-62.5-XSR			3/8"	1-1/2"	60
3-1/2"	1-3/8"	225	W-63.5-XSR			3/8"	1-1/2"	60
4"	1-3/8"	225	W-64-XSR			3/8"	1-1/2"	60
4"	1-3/8"	300	W-74-XSR			3/8"	1-3/4"	70
5"	1-3/8"	275	W-65-XSR			3/8"	1-1/2"	60
5"	1-3/8"	350	W-75-XSR			3/8"	1-3/4"	70
6"	1-1/2"	400	W-76-XSR			3/8"	1-3/4"	70



W-406-PSE

- Shore Hardness 55 + 1 "D" Scale
- Temperature Ranges -40°F to 230°F.
- Resistant to Wide Range of Chemicals.
- A must for tow line applications.
- Extraordinarily easy to push.
- Shows minimal wear in extended use.
- Shock absorbing and extremely quiet.
- Resists abrasion and many hazardous chemicals.
- Displays extremely low heat build-up in continuous use.
- No maintenance required for precision bearings.
- No flat spotting.

ROLLABILITY TESTS DARCOR "SE" VS THE COMPETITION

Tests were conducted using a platform truck equipped with two swivel and two rigid 6 x 2 casters loaded with a total of 2150 pounds (537 per caster). The effort required to start and maintain the truck in motion was measured. The swivelling test was conducted by aligning the two swivel casters at 90° to the direction of travel.

Each test was conducted three times and the results averaged. Variations of twenty percent were common. The greatest variation was experienced when the forces required were greater than eighty pounds due to the physical effort required. All tests were conducted manually with appropriate force gauges, and roller bearings in the wheel.

The ranking of the various wheels gave the greatest weight to starting and rolling. It was felt that swivelling could be affected by the shape of the tread and would not be as valid an indication of performance.

TEST RESULTS

RANK	MANUFACTURER & TYPE OF WHEEL	HARDNESS SHORE D	LOAD LBS	START LBS	ROLL LBS	SWIVEL LBS
#1	DARCOR Solid Wheel - SE	55 ^o	2150	16	11	65
#2	DARCOR TD NEOPRENE	60-65 ^A	2150	26	24	115
#3	DARCOR Cast Iron Core - Cast Urethane	55	2150	34	25	120
#4	Competitor #1 Aluminium Core-Moulded Wheel	58	2150	35	25	130
#5	Competitor #2 Solid Wheel	60	2150	38	26	80
#6	Competitor #3 Thermoplastic Core - Thermoplastic Rubber	67 ^A	2150	43	27	117
#7	DARCOR Solid Wheel - Hard Rubber	78 ^o	2150	44	33	66
#8	Competitor #4 Aluminium Core - Cast Urethane	40-100	2150	44	38	145
#9	Competitor #5 Thermoplastic Core - Thermoplastic Urethane	50-60	2150	58	53	130
#10	Competitor #6 Thermoplastic Core - Thermoplastic Urethane	40-70	2150	63	49	130
#11	Competitor #7 Solid Wheel - Cast Urethane	60	2150	66	52	135
#12	Competitor #8 Aluminium Core - Thermoplastic Urethane	60	2150	120	90	150

DATRYL, as used in the "SE" WHEEL, is a proprietary blend of elastomers and other constituents to produce a wheel which we believe is superior in performance to conventional urethane, hard rubber and Phenolic wheels.

WHEEL DIAMETER	TREAD WIDTH	LOAD CAPACITY	BALL BEARING	PRECISION SEALED BALL BEARING	BORE SIZE	HUB LENGTH	USED IN CASTER SERIES
2-1/2"	1-1/4"	300	W-62.5-XSE		3/8"	1-1/2"	60
3"	1-3/8"	500		W-73-PSE	3/8"	1-3/4"	70
	2"	900		W-403-PSE	1/2"	2-5/16"	400
3-1/2"	1-1/4"	350	W-63.5-XSE		3/8"	1-1/2"	60
4"	1-3/8"	600		W-74-PSE	3/8"	1-3/4"	70
	2"	1000		W-404-PSE	1/2"	2-5/16"	400
5"	1-3/8"	700		W-75-PSE	3/8"	1-3/4"	70
	2"	1000		W-405-PSE	1/2"	2-5/16"	400
	2-1/2"	1350		W-805-PSE	3/4"	2-3/4"	700/800
6"	1-3/8"	750		W-76-PSE	3/8"	1-3/4"	70
	2"	1100		W-406-PSE	1/2"	2-5/16"	400
	2-1/2"	1500		W-806-PSE	3/4"	2-3/4"	700/800
8"	2"	1200		W-408-PSE	1/2"	2-5/16"	400
	2-1/2"	1650		W-808-PSE	3/4"	2-3/4"	700/800
10"	2-1/2"	1800		W-810-PSE	3/4"	2-3/4"	700/800

URETHANE WHEELS

TREAD SYMBOL "U"

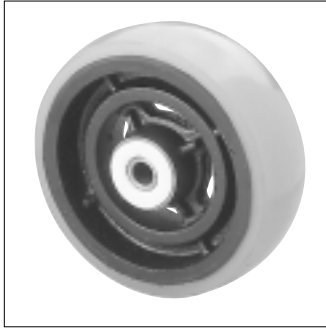

W-406-TU

Shore Hardness: 95 "A" Scale
 A Urethane Tread moulded and bonded to a steel core. Recommended for heavy loads and rough floor conditions. Resistant to a wide range of chemicals, oils and solvents.
 Withstands temperature ranges from 25°F below 0 up to 200°F.
 Resists abrasion and flat spotting.

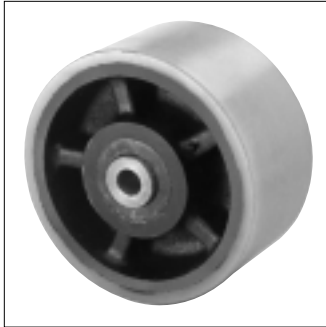

W-8510-YU

WHEEL DIAMETER	TREAD WIDTH	LOAD CAP./LBS	ROLLER BEARING	TAPERED BEARING	BORE SIZE	HUB LENGTH	USED IN CASTER SERIES
3-1/2"	2"	800	W-403.5-TU		1/2"	2-5/16"	400
4"	1-3/8"	600	W-74-TU		3/8"	1-3/4"	70
4"	2"	900	W-404-TU		1/2"	2-5/16"	400
5"	1-3/8"	600	W-75-TU		3/8"	1-3/4"	70
5"	2"	1000	W-405-TU		1/2"	2-5/16"	400
6"	1-3/8"	600	W-76-TU		3/8"	1-3/4"	70
6"	2"	1000	W-406-TU		1/2"	2-5/16"	400
6"	2-1/4"	1500	W-806-TU		3/4"	2-3/4"	700/800
6"	3"	2500	W-5006-TU	W-5006-YU	3/4", 1"	3-3/8"	900, 5000, 5200
8"	2"	1000	W-408-TU		1/2"	2-5/16"	400
8"	2-1/2"	1800	W-808-TU		3/4"	2-3/4"	700/800
8"	3"	3000	W-5008-TU	W-5008-YU	3/4", 1"	3-3/8"	900, 5000, 5200
10"	3"	3500	W-5010-TU	W-5010-YU	3/4", 1"	3-3/8"	900, 5000, 5200
10"	4"	8000		W-8010-YU	1-1/2"	4-1/2"	WHEEL ONLY
10"	5"	10,000		W-8510-YU	1"	5-1/2"	SL-8510
12"	3"	4000	W-5012-TU	W-5012-YU	3/4", 1"	3-1/4"	900,5000,5200
16"	5"	8400		W-8016-YU	1-1/2"	5-1/2"	8216

Additional Bore Sizes available.

400 Series - 3/4"

700 Series - 1/2", 1"

5000 Series - 1-1/4"

SEMI-STEEL WHEELS

TREAD SYMBOL "CI"



W-406-TCI

A Semi-Steel Casting of a close-grained high tensile iron. All Wheels are crowned to help prevent floor damage, and improve swiveling. Also available in "Grooved" type for inverted angle iron applications. See Page 36.

WHEEL DIAMETER	TREAD WIDTH	LOAD CAP./LBS	SLEEVE BEARING	ROLLER BEARING	TAPERED BEARING	BORE SIZE	HUB LENGTH	USED IN CASTER SERIES
2"	1"	100	W-22-CI			5/16"	1-1/8"	20
2-1/2"	1"	125	W-22.5-CI			5/16"	1-1/8"	20
2-1/2"	1-1/4"	400	W-62.5-CI			3/8"	1-1/2"	60
3"	1-3/8"	400	W-63-CI			3/8"	1-1/2"	60
3"	1-3/8"	500	W-73-CI	W-73-TCI		3/8"	1-3/4"	70
3"	1-7/8"	900		W-403-TCI		1/2"	2-5/16"	400
3-1/2"	1-3/8"	400	W-63.5-CI			3/8"	1-1/2"	60
4"	1-3/8"	400	W-64-CI			3/8"	1-1/2"	60
4"	1-3/8"	600	W-74-CI	W-74-TCI		3/8"	1-3/4"	70
4"	1-7/8"	1000		W-404-TCI		1/2"	2-5/16"	400
5"	1-3/8"	400	W-65-CI			3/8"	1-1/2"	60
5"	1-3/8"	600	W-75-CI	W-75-TCI		3/8"	1-3/4"	70
5"	1-7/8"	1000		W-405-TCI		1/2"	2-5/16"	400
5"	2-1/4"	1500		W-805-TCI		3/4"	2-3/4"	700/800
6"	1-3/8"	600	W-76-CI			3/8"	1-3/4"	70
6"	1-7/8"	1000		W-406-TCI		1/2"	2-5/16"	400
6"	2-1/4"	1700		W-806-TCI		3/4"	2-3/4"	700/800
6"	3"	5000		W-5006-TCI	W-5006-YCI	3/4", 1"	3-3/8"	900, 5000, 5200
8"	1-7/8"	1000		W-408-TCI		1/2"	2-5/16"	400
8"	2-1/4"	1800		W-808-TCI		3/4"	2-3/4"	700/800
8"	3"	5000		W-5008-TCI	W-5008-YCI	3/4", 1"	3-3/8"	900, 5000, 5200
10"	2-1/4"	2200		W-810-TCI		3/4"	2-3/4"	700/800
10"	3"	5000		W-5010-TCI	W-5010-YCI	3/4", 1"	3-3/8"	900, 5000, 5200
12"	3"	5000		W-5012-TCI	W-5012-YCI	3/4", 1"	3-3/8"	900, 5000, 5200

Additional Bore Sizes available:

400 Series - 3/4"

700 Series - 1/2", 1"

5000 Series - 1-1/4"

RUBBER WHEELS

TREAD SYMBOL " K "

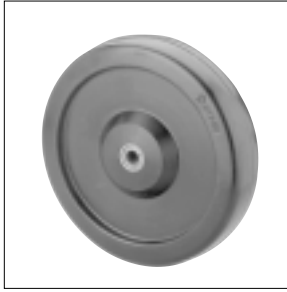

W- 75-K

Shore Hardness: 85-90 "A" Scale.
Semi resilient rubber. A tough robust wheel.
Recommended for temperature ranges from 0°F to 110°F.

WHEEL DIAMETER	TREAD WIDTH	LOAD CAP./LBS	SLEEVE BEARING	BALL BEARING	BORE SIZE	HUB LENGTH	USED IN CASTER SERIES
2"	1"	75	W-22-K		5/16"	1-1/8"	20
2-1/2"	1"	75	W-22.5-K		5/16"	1-1/8"	30
2-1/2"	1"	100		W-32.5-XK	5/16"	1-1/8"	30
3"	1"	75	W-23-K		5/16"	1-1/8"	30
3-1/2"	1-3/8"	150	W-63.5-K		3/8"	1-1/2"	60
4"	1"	75	W-24-K		5/16"	1-1/8"	20
4"	1-3/8"	175	W-64-K		3/8"	1-1/2"	60
4"	1-3/8"	300	W-74-K		3/8"	1-3/4"	70
5"	1-3/8"	175	W-65-K		3/8"	1-1/2"	60
5"	1-3/8"	300	W-75-K		3/8"	1-3/4"	70
6"	1-3/8"	300	W-76-K		3/8"	1-3/4"	70

HARD RUBBER WHEELS

TREAD SYMBOL " H "



W-75-H

An extremely durable synthetic rubber material formed under very high pressure.
Tremendous wearing characteristics.
Shore Hardness: 78 "D" Scale.
NOT affected by oil, grease, water, gas or cleaning compounds.
Non-Conductive.
Temperature range 110°F max. to -40°F.
Not recommended for use on tile.
Identification: Brown in colour.

WHEEL DIAMETER	TREAD WIDTH	LOAD CAP./LBS	SLEEVE BEARING	BALL BEARING	BORE SIZE	HUB LENGTH	USED IN CASTER SERIES
2"	1"	100	W-22-H	W-22-XH	5/16"	1-1/8"	20
2"	1"	150		W-32-XH	5/16"	1-1/8"	30
2-1/2"	1"	125	W-22.5-H		5/16"	1-1/8"	20
2-1/2"	1"	150		W-32.5-XH	5/16"	1-1/8"	30
3"	1"	125	W-23-H		5/16"	1-1/8"	20
3"	1-3/8"	350	W-63-H		3/8"	1-1/2"	60
3"	1-3/8"	500	W-73-H		3/8"	1-3/4"	70
3-1/2"	1-3/8"	375	W-63.5-H		3/8"	1-1/2"	60
4"	1"	125	W-24-H		5/16"	1-1/8"	20
4"	1-3/8"	400	W-64-H		3/8"	1-1/2"	60
4"	1-3/8"	550	W-74-H		3/8"	1-3/4"	70
5"	1-3/8"	400	W-65-H		3/8"	1-1/2"	60
5"	1-3/8"	600	W-75-H		3/8"	1-3/4"	70
6"	1-3/8"	600	W-76-H		3/8"	1-3/4"	70

INDUSTRIAL WHEELS

TREAD SYMBOL " N "

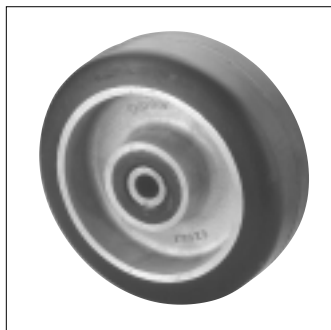

W-908-TN

Aluminium core with roller bearing and protective outer seal.
 Black natural rubber tread bonded to core.
 Hardness - 70 Shore 'A'
 Tread resists chipping and abrasion as well as flat spotting.
 High quality natural rubber allows for ease in mobility.

WHEEL DIAMETER	TREAD WIDTH	LOAD CAP./LBS	ROLLER BEARING	TAPERED BEARING	BORE SIZE	HUB LENGTH	USED IN CASTER SERIES
6"	3"	700	W-906-TN	W-906-YN	3/4"	3-3/8"	900, 5200
8"	3"	900	W-908-TN	W-908-YN	3/4"	3-3/8"	900, 5200
10"	3"	1100	W-910-TN	W-910-YN	3/4"	3-3/8"	900, 5200
12"	3"	1200	W-912-TN	W-912-YN	3/4"	3-3/8"	900, 5200
14"	3"	1350	W-914-TN	W-914-YN	3/4"	3-3/8"	WHEEL ONLY
16"	3"	1550	W-916-TN	W-916-YN	3/4"	3-3/8"	WHEEL ONLY

Optional Bore sizes: 1", 1-1/4"

"1-1/4" Bore is not supplied with a hardened spanner bushing

PNEUMATIC WHEELS

TREAD SYMBOL " PN "



W-3118-YPN

Fully Pneumatic with separate inner tube and wheel discs of heavy gauge metal.
 Polyurethane filling is available.
 Pneumatics do require inflation.
 Lubrication through nipple in hub.

WHEEL DIAMETER	TREAD WIDTH	LOAD CAP./LBS	MAX. AIR PRESSURE	ROLLER BEARING	TAPERED BEARING	BORE SIZE	HUB LENGTH	USED IN CASTER SERIES
8"	2-3/8"	300	100 PSI	W-308-TPN		1/2", 3/4"	3-1/4"	300
10"	3-5/8"	350	80 PSI	W-310-TPN		1/2", 3/4"	3-1/4"	300
16"	4-1/2"	750	70 PSI		W-3116-YPN	5/8"	4-1/4"	3100, 3200
18"	5-3/4"	900	60 PSI		W-3118-YPN	5/8"	4-1/4"	3100, 3200, 3300

NON-MARKING PROTECTIVE BUMPERS

PROTECTS WALLS AND EQUIPMENT



C-1676

C-1676 Corner Bumpers
Made especially for use with C-567 Strip Bumper to give a uniform continuous effect all around the equipment.



C-833

C-833 Corner Bumper
Made to give adequate protection to all surfaces that may be contacted, such as doors, door facings, walls, furniture, and other equipment. Easily attached by using self-tapping sheet metal screws.

C-813 Donut Bumpers
Commonly installed on the ends of tubular handles to give needed protection in manipulation of equipment. Note: steel insert around mounting hole. Attached to wood with wood screws or to metal with rivets, bolts, or metal screws.



C-813

Model C-567 Strip Bumper
A flat based rubber strip bumper designed for installation on either metal or wood surfaces. This model is easily applied and does not require a special channel.

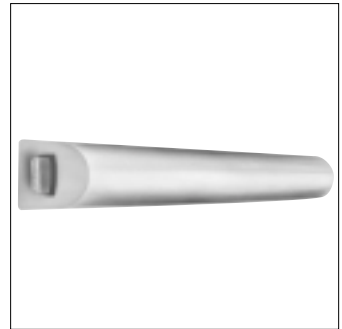

C-567

(MI-500- Flat Bar Metal Inserts 1/8" x 1/2" for C-567, ordered separately, subject to cutting charge).

FLOOR LOCKS

SECURES LOAD IN POSITION



634

HOW TO OPERATE FLOOR LOCKS

Press down to lock. Press down to release. Double non-slip pedals.

Simply press down on larger pedal to set positive lock. (This moves second pedal into top or up position.)

Press down on release pedal and spring quickly returns lock to non-operating position. Both pedals are out in front for safety and ease of operation.

INSTALLATION RECOMMENDATIONS FOR CASTER & FLOOR LOCK.

It is important to select a Caster with an overall height to permit the floor lock to clear the floor in retracted position. The clearance between floor and floor lock rubber pad should be minimal in order to use as much pressure from spring locking device. This will ensure better holding pressure from lock.

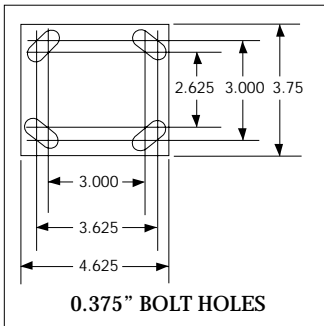

No. 31 Top Plate

MODEL NUMBER	EXTENDED HEIGHT	RETRACTED HEIGHT
558	5-5/8"	5"
614	6-1/4"	5-5/8"
634	6-3/4"	6-1/8"
734	7-3/4"	7"

ABRASION RESISTANCE:	The ability of a wheel to resist wear due to use with various floor materials.
AXLE & NUT:	Retains wheels in the yoke.
BOLT HOLE SPACING:	The distance from the centre of one bolt hole to the centre of the next. Where slotted bolt holes are used, two dimensions will be shown.
BORE SIZE:	The axle diameter required for installing a wheel.
CASTER:	One complete unit consisting of all basic caster components: top plate, yoke, wheel, wheel bearing, thread guards, axle nut and washer.
CHEMICAL RESISTANCE:	The degree to which a wheel or tread material is affected when exposed to chemicals.
COMPLETE WHEEL:	The wheel, wheel bearing and related parts, and thread guards.
COMPRESSION SET:	(Also referred to as set or flat spotting.) The effect on a wheel, under load, after a given period of time.
CONDUCTIVE WHEELS:	Measurement of a wheel material's ability to dissipate static electricity (as in anti-static or spark proof wheels).
CROWN:	The Radius molded or machined on the periphery of the wheel to reduce swivelling effort.
DUROMETER (HARDNESS):	SYSTEM for establishing how hard or soft a wheel is. Measured as shore hardness on either the "A" scale for softer tread materials, or the "D" scale for harder tread materials.
DUSTCAP:	Encloses the hardcap to protect the raceway from foreign materials.
DYNAMIC LOAD:	The maximum load on a caster in motion under normal conditions.
ERGONOMICS:	A way of thinking about the design of tools and equipment, the layout of workplaces, and the overall organization of work. The goal of ergonomics is the realization of production and health/safety benefits by fitting the job to the person rather than making the person fit the job.
	
HARDCAP:	The thrust bearing upper raceway.
HUB LENGTH:	The distance from one edge of the hub (axle opening) to the other.
KING BOLT OR RIVET:	Holds swivel components together. A King Bolt is threaded with a nut tightened over the lower end of the swivel. A rivet is either staked through, or orbitally connected to the swivel.
LOAD CAPACITY:	The recommended maximum weight to be carried by a single caster or wheel.
MOBILITY:	Defines the degree of freedom of movement.
OVERALL HEIGHT:	The vertical distance between the top of the caster mounting plate and the bottom of the wheel. When using a stem, this dimension is reduced by the thickness of the top plate.
RESILIENCY:	The amount of spring or bounce in a wheel and the resulting effect on rolling resistance.
RIGID CASTER:	A basic caster unit which does not swivel.
ROLLING RESISTANCE:	The amount of effort required to move a load usually measured in pounds of force.
SHOCK LOAD:	The maximum load a caster can withstand under shock conditions.
SOLID ELASTOMER:	A breakthrough advance in wheel technology, exclusive to Darcor. Solid elastomer wheels are renowned for low rolling resistance, imperviousness to harsh chemicals, and perfect shape retention even after long-term exposure to temperature and load extremes.
STATIC LOAD:	The maximum load on a caster when movement or shock are not present.
SWIVEL CASTER:	A basic caster unit with the addition of a bearing that allows the caster to swivel about a vertical axis.
SWIVEL RACEWAY:	The part of the swivel that contains the bearings.
SWIVEL RADIUS:	The radius required for a caster to swivel freely. Determined by measuring from the centre of the King Bolt to the outside of the wheel.
TEMPERATURE RANGE:	The maximum temperature range that a wheel can operate within for a period of time and still maintain its characteristics.
THREAD GUARDS:	(Also known as string guards.) Keep foreign materials away from axle and bearings.
TOP PLATE OR STEM:	Elements for attaching a caster to a piece of equipment.
TOP PLATE SIZE:	Determined by measuring from one outside edge to the other outside edge.
TREAD WIDTH:	The distance between the outermost edges of the wheel.
WHEEL BEARINGS:	Various types of bearings available.
WHEEL SIZE:	Determined by the diameter of the wheel.
YOKE:	Supports upper and lower raceways. A rigid yoke is either a top plate with legs welded to it or a formed, single-piece top plate/yoke combination.